



# **A TUTORIAL: Improving the Seismic Performance of Stone Masonry Buildings**

**Jitendra Bothara • Svetlana Brzev**

---

First Edition, April 2011





**A TUTORIAL:  
Improving the Seismic Performance  
of Stone Masonry Buildings**

**Jitendra Bothara  
Svetlana Brzev**

**First Edition, April 2011**

**Publication Number WHE-2011-01**



© 2011 Earthquake Engineering Research Institute, Oakland, California 94612-1934.

All rights reserved. No part of this book may be reproduced in any form or by any means without the prior written permission of the publisher, Earthquake Engineering Research Institute, 499 14th St., Suite 320, Oakland, CA 94612-1934.

This report is published by the Earthquake Engineering Research Institute, a nonprofit corporation. The objective of the Earthquake Engineering Research Institute is to reduce earthquake risk by advancing the science and practice of earthquake engineering by improving understanding of the impact of earthquakes on the physical, social, economic, political, and cultural environment, and by advocating comprehensive and realistic measures for reducing the harmful effects of earthquakes.

Production of this tutorial has been supported in part by generous contributions from the New Zealand Society for Earthquake Engineering and the Earthquake Engineering Center of the University of Engineering and Technology, Peshawar, Pakistan.

This tutorial was written and reviewed by volunteers, all of whom participate in EERI and IAEE's World Housing Encyclopedia project. Any opinions, findings, conclusions, or recommendations expressed herein are the authors' and do not necessarily reflect the views of their organizations.

Copies of this publication may be ordered from:

Earthquake Engineering Research Institute  
499 14th Street, Suite 320  
Oakland, CA 94612-1934 USA  
Telephone: 510/451-0905  
Fax: 510/451-5411  
E-mail: [eeri@eeri.org](mailto:eeri@eeri.org)  
Web site: [www.eeri.org](http://www.eeri.org)

ISBN: 978-1-932884-48-7

EERI Publication Number WHE-2011-01

**Technical Editor:** Andrew Charleson

**Production coordinators:** Svetlana Brzev, Marjorie Greene, Ruben Negrete, Emmett Seymour

**Layout & Design:** Rachel Beebe

**Illustrators:** Ruslan Idrisov, Simon John Harrison

**Cover Photo:** The construction of the Kuleshwor Primary School in the Thumki village, Kaski District, Nepal. The building was built by the Smart Shelter Foundation and uses stone, since it is a locally available material. The building is located at 1100 m elevation in a hilly area close to the mountains (photo: Smart Shelter Foundation)

---

## Acknowledgments

This tutorial has been developed and reviewed by an international team of experts, who volunteered their time and knowledge to develop this document over the last three years. The primary authors are Jitendra Bothara (New Zealand) and Svetlana Brzev (Canada). The authors are particularly grateful to those who provided many useful suggestions as reviewers. The authors are especially grateful to Qaisar Ali (Pakistan) and Tom Schacher (Switzerland) for performing a thorough review of the manuscript and contributing photographs. The authors would like to acknowledge the individuals and organizations who provided useful review comments and contributed photographs and illustrations, including Marjana Lutman and Miha Tomazevic (Slovenia), Martijn Schildkamp (Smart Shelter Foundation), Randolph Langenbach (U.S.A.), Mohammed Farsi (Algeria), Stavroula Pantazopoulou (Greece), Krishna Vasta (India), and Robert Culbert, Builders Without Borders (Canada). The authors appreciate valuable feedback provided by Mel Green (U.S.A.). The authors of all the various WHE housing reports cited in this tutorial provided much useful information in their reports, for which the authors are very grateful.

The authors are grateful to C.V.R. Murty (India), former WHE Editor-in-Chief, who supported the idea of developing this tutorial and contributed in the early stages of its development. Special thanks are due to Andrew Charleson, current WHE Editor-in-Chief who served as the Technical Editor of this publication and has reviewed its many drafts. This publication would not have been possible without Marjorie Greene (EERI) and Heidi Faison, WHE Associate Editor, who played a critical role in developing the final draft of the publication. The authors are grateful to Dr Richard Sharpe (New Zealand) for reviewing the final draft of the tutorial on behalf of the New Zealand Society for Earthquake Engineering. The quality of the publication would not be the same without superb illustrations developed by Ruslan Idrisov and Simon John Harrison (New Zealand), and editorial effort by Rachel Beebe (U.S.A.). The authors appreciate contributions by Ruben Negrete and Emmett Seymour, EERI Interns, in the editing stage of this document.

Production of this tutorial has been supported in part by generous contributions from the New Zealand Society for Earthquake Engineering and the Earthquake Engineering Center of the University of Engineering and Technology, Peshawar, Pakistan. The financial support was used to enable the development of graphics and production of this publication.



# WORLD HOUSING ENCYCLOPEDIA EDITORIAL BOARD



**Editor-in-Chief**

**Andrew Charleson**  
Victoria University of Wellington  
New Zealand



**Associate Editor**

**Heidi Faison**  
Pacific Earthquake Engineering Research Center  
U.S.A.

**Managing Editor**

**Marjorie Greene**  
Earthquake Engineering Research Institute  
U.S.A.

**Associate Editor**

**Dominik Lang**  
NORSAR Foundation  
Norway

**Qaisar Ali**

NWFP University of Eng. & Technology  
Pakistan

**Takim Andriano**

Petra Christian University  
Indonesia

**Marcial Blondet**

Catholic University of Peru  
Peru

**Jitendra Bothara**

Beca  
New Zealand

**Svetlana Brzev**

British Columbia Institute of Technology  
Canada

**Craig Comartin**

CD Comartin Inc.  
U.S.A.

**Junwu Dai**

Institute of Engineering Mechanics  
China

**Dina D'Ayala**

University of Bath  
United Kingdom

**Jorge Gutierrez**

University of Costa Rica, Dept. of Civil Engineering  
Costa Rica

**Andreas Kappos**

University of Thessaloniki  
Greece

**Chitr Lilavivat**

Consulting Engineer  
Thailand

**Marjana Lutman**

Slovenian National Bldg. & Civil Eng. Institute  
Slovenia

**Leo Massone**

University of Chile  
Chile

**C.V.R. Murty**

Indian Institute of Technology Madras  
India

**Farzad Naeim**

John A. Martin & Associates  
U.S.A.

**Tatsuo Narafu**

Japan International Cooperation Agency  
Japan

**Sahar Safaie**

The World Bank  
U.S.A.

**Baitao Sun**

Institute of Engineering Mechanics  
China

**Sugeng Wijanto**

Trisakti University  
Indonesia

---

## WORLD HOUSING ENCYCLOPEDIA CONTRIBUTORS

Abdibaliev, Marat  
Agarwal, Abhishek  
Ahari, Masoud Nourali  
Ait-Méziane, Yamina  
Ajamy, Azadeh  
Al Dabbeek, Jalal N.  
Alcocer, Sergio  
Alemi, Faramarz  
Alendar, Vanja  
Ali, Qaisar  
Alimoradi, Arzhang  
Al-Jawhari, Abdel Hakim W.  
Almansa, Francisco López  
Al-Sadeq, Hafez  
Ambati, Vijaya R.  
Ambert-Sanchez, Maria  
Ansary, Mehedi  
Arnold, Chris  
Arze L., Elias  
Aschheim, Mark  
Ashimbayev, Marat U.  
Ashtiany, Mohsen Ghafory  
Astroza, Maximiliano  
Awad, Adel  
Azarbakht, Alireza  
Bachmann, Hugo  
Baharudin, Bahiah  
Bassam, Hwaija  
Bazzurro, Paolo  
Begaliev, Ulugbek T.  
Belash, Tatyana  
Benavidez, Gilda  
Benin, Andrey  
Bento, Rita  
Bhatti, Mahesh  
Bin Adnan, Azlan  
Blondet, Marcial  
Bogdanova, Janna  
Bommer, Julian  
Bostenaru Dan, Maria  
Bothara, Jitendra Kumar  
Brzev, Svetlana  
Cardoso, Rafaela  
Castillo G., Argimiro  
Ceï, Chiara  
Chandrasekaran, Rajarajan  
Charleson, Andrew  
Chernov, Nikolai Borisovich  
Cherry, Sheldon  
Choudhary, Madhusudan  
Cleri, Anacleto  
Comartin, Craig  
D'Ayala, Dina  
D'Ercole, Francesco  
Davis, Ian  
Deb, Sajal K.  
Desai, Rajendra  
Diaz, Manuel  
Dimitrijevic, Radovan  
Dowling, Dominic  
Eisenberg, Jacob  
Eisner, Richard  
Ellul, Frederick  
Elwood, Kenneth  
Faison, Heidi  
Farsi, Mohammed  
Feio, Artur  
Fischinger, Matej  
French, Matthew A.  
Gómez, Cristian  
Gordeev, Yuriy  
Goretti, Agostino  
Goyal, Alok  
Greene, Marjorie  
Guevara-Perez, Teresa  
Gülkan, Polat  
Gupta, Brijbhushan J.  
Gutierrez, Jorge A.  
Hachem, Mahmoud M.  
Hashemi, Behrokh Hosseini  
Irfanoglu, Ayhan  
Itskov, Igor Efroimovich  
Jain, Sudhir K.  
Jaiswal, Kishor S.  
Jarque, Francisco Garcia  
Kante, Peter  
Kappos, Andreas  
Kaviani, Peyman  
Khakimov, Shamil  
Khan, Akhtar Naeem  
Khan, Amir Ali  
Kharrazi, Mehdi H. K.  
Klyachko, Mark  
Kolossova, Freda  
Koumoussis, Vlasis  
Krimgold, Fred  
Kumar, Amit  
Lacava, Giuseppe  
Lang, Kerstin  
Lazzali, Farah  
Leggeri, Maurizio  
Levtchitch, Vsevollod  
Lilavivat, Chitr  
Liu, Wen Guang  
Loaiza F., Cesar  
Lopes, Mário  
Lopez, Walterio  
Lopez M, Manuel A.  
Lourenco, Paulo B.  
Lutman, Marjana  
Maki, Norio  
Malvolti, Daniela  
Manukovskiy, V.  
Martindale, Tiffany  
Meguro, Kimiro  
Mehrain, Mehrdad  
Mejía, Luis Gonzalo  
Meli, Roberto P.  
Moin, Khalid  
Mollaioli, Fabrizio  
Moroni, Ofelia  
Mortchikchin, Igor  
Mucciarella, Marina  
Muhammad, Taj  
Muravljov, Nikola  
Murty, C. V. R.  
Naeim, Farzad  
Naito, Clay J.  
Ngoma, Ignasio  
Nienhuys, Sjoerd  
Nimbalkar, Sudhir  
Nudga, Igor  
Nurtaev, Bakhtiar  
Olimpia Niglio, Denise U.  
Ordonez, Julio  
Ortiz R, Juan Camilo  
Osorio G., Laura Isabel  
Ottazzi, Gianfranco  
Palanisamy, Senthil Kumar  
Pantelic, Jelena  
Pao, John  
Papa, Simona  
Parajuli, Yogeshwar Krishna  
Pradhan, Prachand Man  
Pundit, Jeewan  
Quiun, Daniel  
Rai, Durgesh  
Reiloba, Sergio  
Rodriguez, Virginia I  
Rodriguez, Mario  
Samant, Laura  
Samanta, R. Bajracharya  
Samaroo, Ian  
Sandu, Ilie  
Saqib, Khan  
Sassu, Mauro  
Schwarzmueller, Erwin  
Shabbir, Mumtaz  
Sharpe, Richard  
Sheth, Alpa  
Sheu, M.S.  
Singh, Narendrapal  
Singh, Bhupinder  
Sinha, Ravi  
Skliros, Kostas  
Smillie, David  
Sophocleous, Aris  
Sanchez, De la Sotta  
Spence, Robin  
Speranza, Elena  
Sun, Baito  
Syrmakezis, Kostas  
Taghi Bekloo, Nima  
Talal, Isreb  
Tanaka, Satoshi  
Tassios, T. P.  
Tomazevic, Miha  
Tuan Chik, Tuan  
Norhayati  
Tung, Su Chi  
Upadhyay, Bijay Kumar  
Uranova, Svetlana  
Valluzzi, Maria Rosa  
Ventura, Carlos E.  
Vetturini, Riccardo  
Viola, Eugenio  
Wijanto, Sugeng  
Xu, Zhong Gen  
Yacante, María I  
Yakut, Ahmet  
Yao, George C.  
Zhou, Fu Lin

---

---

# About the World Housing Encyclopedia

The World Housing Encyclopedia (WHE) is a project of the Earthquake Engineering Research Institute and the International Association for Earthquake Engineering. Volunteer earthquake engineers and housing experts from around the world participate in this web-based project by developing reports on housing construction practices in their countries. In addition, volunteers prepare tutorials on various construction technologies and donate time on various special projects, including a collaborative project to generate information on global construction types with the U.S. Geological Survey, and an initiative to promote confined masonry construction. The WHE is also a partner of the World Bank's Safer Homes Stronger Communities project. All information provided by the volunteers is peer-reviewed. Visit [www.world-housing.net](http://www.world-housing.net) for more information.

Andrew Charleson  
*Editor-in-Chief*  
*February 2011*

---

# About the Tutorial

Durable and locally available, stone has been used as a construction material since ancient times. Stone houses, palaces, temples, and important community and cultural buildings can be found all over the world. With the advent of new construction materials and techniques, the use of stone has substantially decreased in the last few decades. However, it is still used for residential buildings in parts of the world where stone is abundantly available and alternative materials are unaffordable.

Historically, most types of traditional stone masonry have proven to be extremely vulnerable to earthquake shaking. The main reason for poor performance is not the strength of the material but the lack of proper connections both between the stones as well as between various parts of the building. This tutorial on stone masonry therefore focuses primarily on ways to improve the overall integrity of stone masonry buildings in order to improve their seismic capacity. With the help of a number of pictures and sketches, we present several relatively affordable stone masonry construction techniques that have been proven to be earthquake-resistant by traditional experience as well as scientific research results.

As stone masonry has been used for centuries in many countries around the world, there are numerous distinctly different construction techniques. These are strongly influenced by the construction materials and skills available in the area and the financial situation of the building owner. Even in small geographic areas, very different construction techniques for walls, floors, and roofs can be observed. Therefore, developing a tutorial that elaborates on all possible techniques used worldwide would be extremely difficult, if not impossible. Moreover, the resulting tutorial would be too cumbersome to be used effectively, particularly in the field. Consequently, the scope of this tutorial has been limited to discussing stone masonry techniques used primarily in the earthquake-vulnerable countries of Asia, mostly South Asia. Nevertheless, an effort has also been made to include some stone masonry construction techniques used in other parts of the world, including Europe and Latin America. For more details on these, readers are referred to reports published in the World Housing Encyclopedia ([www.world-housing.net](http://www.world-housing.net)).

## Scope of the Tutorial

It is expected that this tutorial will fill a gap in the perceived lack of information about the earthquake-resistant construction of stone masonry buildings in developing countries, particularly in South Asia. The focus is on random rubble stone construction. The tutorial covers the behavior of stone masonry buildings in earthquakes, discusses the reasons behind their poor performance, and provides techniques to improve the seismic performance of stone masonry houses. While aimed at South Asia, the tutorial nevertheless also covers topics which could be helpful to professionals involved in stone masonry construction elsewhere.

The target groups for this tutorial are:

- Field level engineers/ technicians
- Engineering/ polytechnic students

It is also expected that this tutorial will provide useful reference material for engineering and polytechnic institutes. An extensive bibliography provides a wealth of knowledge sources on stone masonry.



---

# Contents

<b>1.</b>	<b>INTRODUCTION</b>	<b>1</b>
	Stone Masonry Construction Around the World	1
	Key Building Components	3
	Stone Masonry Wall Construction Practices	8
<b>2.</b>	<b>SEISMIC DEFICIENCIES AND DAMAGE PATTERNS</b>	<b>15</b>
	Lack of Structural Integrity	16
	Delamination of Wall Wythes	22
	Out-of-Plane Wall Collapse	24
	In-Plane Shear Cracking	27
	Poor Quality of Construction	28
	Foundation Problems	29
<b>3.</b>	<b>STONE MASONRY CONSTRUCTION WITH IMPROVED EARTHQUAKE PERFORMANCE</b>	<b>31</b>
	Building Site	32
	Building Configuration	32
	Structural Integrity (Box Action)	33
	Seismic Bands (Ring Beams)	34
	Stone Masonry Walls	39
	Floor and Roof Construction	44
	Foundations	46
	Construction Materials	47
<b>4.</b>	<b>RETROFITTING A STONE MASONRY BUILDING</b>	<b>53</b>
	Seismic Retrofitting: Key Strategies and Challenges	53
	Enhancing Building Integrity	54
	Enhancing the Lateral Load Resistance of Stone Masonry Walls	63
	Strengthening Foundations	69
<b>5.</b>	<b>CONCLUSIONS</b>	<b>71</b>
<b>6.</b>	<b>REFERENCES</b>	<b>73</b>
<b>7.</b>	<b>GLOSSARY</b>	<b>77</b>



---

# 1. Introduction

## Stone Masonry Buildings Around the World

Stone masonry is a traditional form of construction that has been practiced for centuries in regions where stone is locally available. Stone masonry has been used for the construction of some of the most important monuments and structures around the world. Buildings of this type range from cultural and historical landmarks, often built by highly skilled stonemasons, to simple dwellings built by their owners in developing countries where stone is an affordable and cost-effective building material for housing construction. Stone masonry

buildings can be found in many earthquake-prone regions and countries including Mediterranean Europe, North Africa, the Middle East, and Southeast Asia. The World Housing Encyclopedia currently contains 15 reports describing stone masonry housing construction practices in Algeria, Greece, India, Iran, Italy, Nepal, Pakistan, Palestinian Territories, Slovenia, and Switzerland (see References section). Examples of stone masonry around the world are shown in Figures 1.1 to 1.6.



**Figure 1.1** Stone masonry buildings in Greece: a) older construction in Northern Greece, and b) recent construction (photos: S. Pantazopoulou)



**Figure 1.2** Stone masonry in Italy: a) castle tower in San Giuliano di Puglia, the village most affected by the 2002 Molise earthquake, and b) a street lined with stone masonry houses in Sermonetta, a village between Rome and Naples (photos: R. Langenbach)



Figures 1.3 Typical stone masonry houses in Turkey (photos: M. Erberik)

Houses of this construction type are found in urban and rural areas around the world. There are broad variations in construction materials and technology, shape, and the number of stories. Houses in rural areas are generally smaller in size and have smaller-sized openings since they are typically used by a single family. Multi-family residential buildings in urban areas are often of mixed use - with a commercial ground floor and a residential area above. Houses in rural areas and suburbs of urban centers are built as detached structures, while housing units in urban centers often share a common wall.

In hilly Mediterranean areas the number of stories varies from two (in rural areas) to five (in urban centers). These buildings have often experienced several interior and exterior repairs and renovations over the course of their useful lives.

Typically, stone masonry houses are built by building owners themselves or by local builders without any formal training. The quality of construction in urban areas is generally superior to that found in rural areas.

*Typically, stone masonry houses are built by the owners themselves or by local builders without any formal training.*



Figure 1.4 Six-story stone masonry building in Algiers, Algeria (photo: S. Brzev)



Figure 1.5 Typical rural housing in Maharashtra, India (photo: S. Brzev)



Figure 1.6 Typical rural housing in Nepal (photo: M. Schildkamp)

## Key Building Components

The key components of a typical stone masonry building include floor/roof systems, walls, and foundations. The walls are vertical elements which support the floors and/or roof, and enclose the building interior. In some cases, a dual gravity load-bearing system is used (Figure 1.7). This system

consists of a timber roof structure supported by timber columns and beams, and stone masonry walls at the exterior. In this case, the walls may not provide support to the floor/roof structure. This type of construction can be found in Maharashtra, India and in Pakistan. It performed poorly in past earthquakes due to the absence of wall-to-roof connections and walls collapsing outward (e.g., the 1993 Maharashtra earthquake, India).

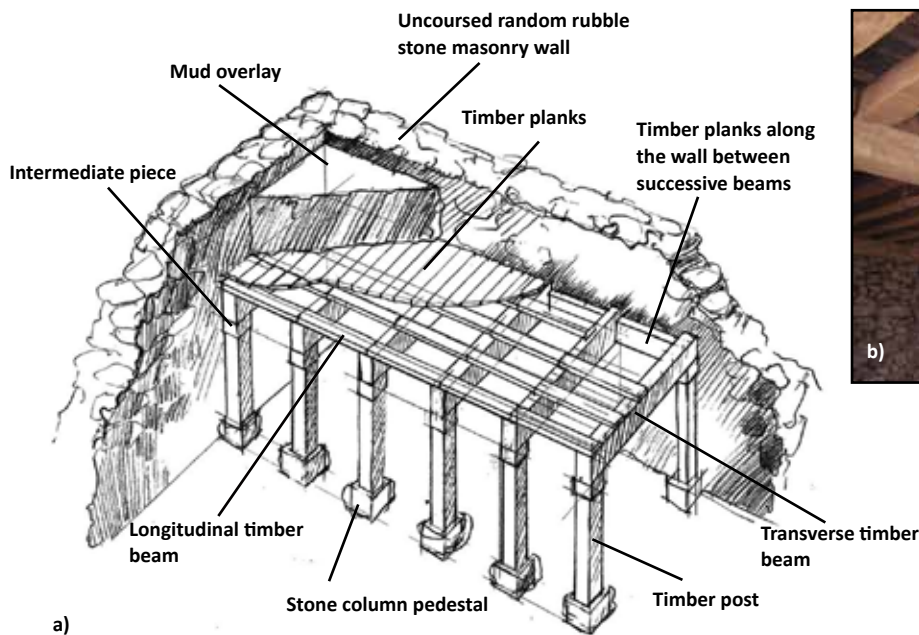

Figure 1.7 Dual gravity load-bearing system: a) a typical stone masonry building with exterior stone masonry walls and an interior timber frame in Maharashtra, India (source: GOM 1998), and b) a stone masonry building with dual system under construction in Pakistan (source: Bothara and Hıçylmaz 2008)

## Floor and Roof Structures

Floor and roof structures in stone masonry construction utilize a variety of construction systems and materials. The choice is often governed by the regional availability and cost of materials, and local artisan skills and experience. Floor and roof systems include masonry vaults, timber joists or trusses, and reinforced concrete slabs.

### Vaulted Floors/Roofs

Brick or stone masonry vaults are typical floor/roof systems found in Mediterranean Europe and the Middle East. Figure 1.8a shows a typical early 20th century floor structure in Slovenia, in which iron beams support shallow brick masonry arches (this is known as a jack arch system), while Figure 1.8b shows a typical 19th century brick masonry vault in Slovenia. In multi-story buildings, jack arches are often found at the ground floor level, and timber joist floors at upper levels. Figure 1.9 shows examples of vaulted floor and roof structures from Italy.

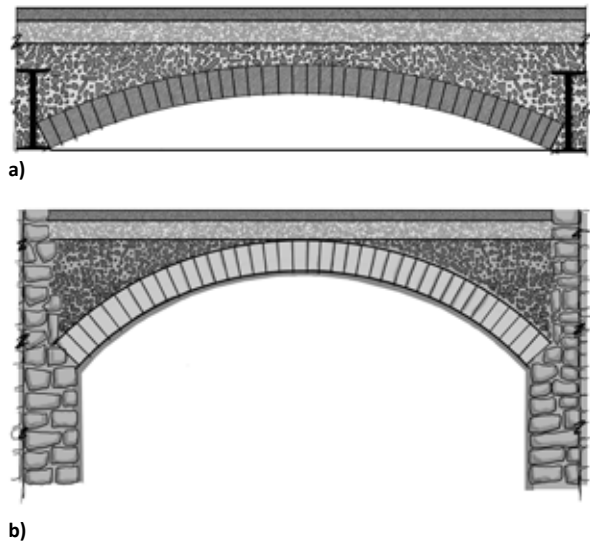

**Figure 1.8** Brick masonry vaults: a) jack arch system, and b) brick masonry vault supported by stone walls (source: M. Lutman)

**Figure 1.9** Vaults in stone masonry buildings in Italy: a) and b) stone masonry vaults in L'Aquila (photos: T. Schacher) and c) an example of a brick vault from Pavia (photo: S. Brzev)



## Timber Joists or Trusses

Timber floor construction may be in the form of wooden beams covered with wooden planks, ballast fill, and tile flooring, as shown in Figure 1.10. A timber floor structure overlaid by planks and bamboo strips is also common (Figure 1.11). In hot climate regions, a thick mud overlay is provided on top of the roof for thermal comfort, as shown in Figure 1.12. Timber truss roofs are common in the area affected by the 2005 Kashmir earthquake in Pakistan, as shown in Figure 1.13. In most cases, timber joists are placed on top of walls without any positive connection; this has a negative effect on seismic performance.

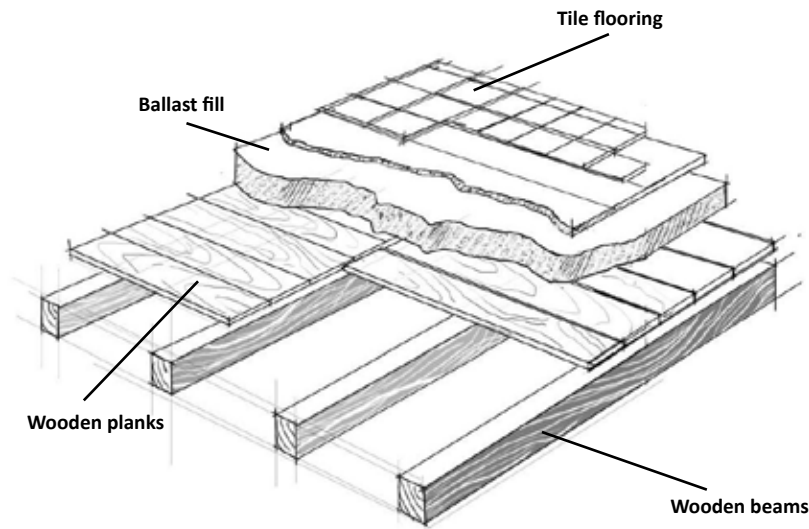

**Figure 1.10** Typical floor construction in Italy with wooden beams and planks, ballast fill, and tile flooring (source: Maffei et al. 2006)



**Figure 1.11** A timber floor structure in Nepal (source: WHE Report 74)



**Figure 1.12** A timber roof structure with mud overlay in Maharashtra, India (photo: S. Brzev)



**Figure 1.13** Timber truss roof structure in the area affected by the 2005 Kashmir earthquake in Pakistan (source: M. Tomazevic 1999)



Figure 1.14 A stone masonry building with an RC slab roof in Pakistan (photo: J. Bothara)

## Reinforced Concrete Floors/Roofs

It is a common structural/seismic rehabilitation practice to replace the original floor structures in historic buildings with either a precast concrete joist system or solid reinforced concrete (RC) slabs; examples of this practice were reported in Italy (WHE Report 28) and Slovenia (WHE Report 58). The use of RC slabs is increasingly popular because cement-based construction materials and technology are becoming widely accessible. An example of a stone masonry building with an RC roof in Pakistan is shown in Figure 1.14. RC slabs are affordable because they require low maintenance and use space efficiently.

Figure 1.15 A stone masonry house built using slate stones in Duao, Chile (photos: S. Brzev)



## Stone Masonry Walls

Stone masonry walls are constructed from stone boulders bonded together with mortar; alternatively, “dry stone masonry” is used when the stones are flat in shape and no mortar is used. Figure 1.15 shows an example of dry stone masonry from Duao, Chile, a small town affected by the February 27, 2010 earthquake (M 8.8) and the subsequent tsunami. This building was located on a beach (the Pacific Ocean can be seen in the background).

In some cases, walls are built using concrete with smaller stone boulders or rubble; this type of composite construction is called “stone-concrete” in India. Concrete construction which uses small stone pieces is known as “plum concrete” (Figure 1.16).

Stone masonry construction practices, including types of stone and wall configurations, are often region-specific. Differences in stone masonry wall construction also depend on economic factors, the availability of quality construction materials, and artisan skills and experience.

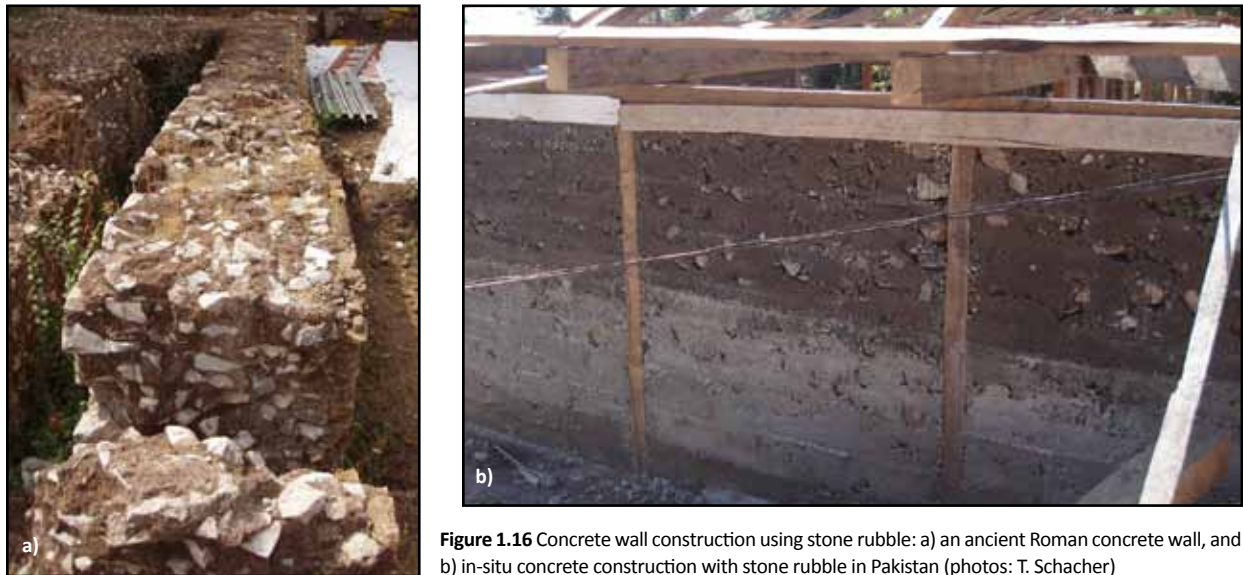

**Figure 1.16** Concrete wall construction using stone rubble: a) an ancient Roman concrete wall, and b) in-situ concrete construction with stone rubble in Pakistan (photos: T. Schacher)

## Foundations

Foundations support the wall weight and provide an interface between the underlying soil and the building structure. In most cases, stone masonry walls are supported by continuous stone masonry strip footings (Figure 1.17). In some cases, footings do not exist at all (Figure 1.18).

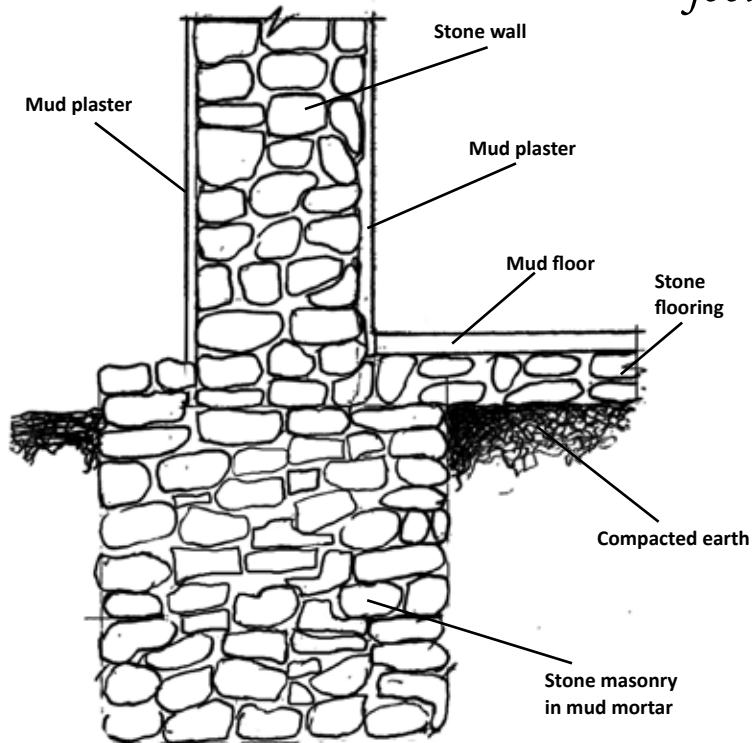

**Figure 1.17** Typical stone masonry foundation in Nepal (source: WHE Report 74)

*In most cases, stone masonry walls are supported by continuous stone masonry strip footings.*



**Figure 1.18** A wall without foundations in the area affected by the 1993 Maharashtra, India, earthquake (photo: S. Brzev)

## Wall Construction Practices

### Types of Stone and Mortar

Stone boulders from various sources, including river stones, field stones, and quarried stones, are used for stone masonry construction. River stones or field stones are often used in their natural round or irregular forms (Figure 1.19); this is especially the case when the materials, expertise, or labor required to shape these stones is difficult to find or excessively expensive. Alternatively, an artisan stone-cutter (see Figure 1.20) can shape stones to produce semi-dressed stones, which have at least one exterior flat surface (wedged stone), as shown in Figure 1.21. In some cases, stones can be fully dressed into regular shapes to better suit construction.

Stone masonry walls are constructed using a variety of mortars, such as mud, lime, or cement/sand mortar. Mud and lime mortars are considered to have low strength. When cement mortar is used, the cement-to-sand ratio is 1:6 or leaner. In some areas, cement mortar has replaced other types because of its increased affordability and availability. The use of cement mortar does not necessarily imply an increase in wall strength, so it often creates a false sense of



**Figure 1.19** Round stone boulders used for traditional stone masonry construction in Padang, Indonesia (photo: J. Bothara)

security in terms of expected superior building performance. As a result, there has been a significant increase in story height and the number and size of openings in stone masonry buildings where cement mortar has been used.



Stone masonry walls can be classified into three types: uncoursed random rubble stone, uncoursed semi-dressed stone, and dressed stone. This classification is made based on the type of stone, extent of shaping, and the layout. In all these wall construction types, common deficiencies include: lean cement mortar, the use of soil or very fine sand mixed with sea sand, and the absence of curing.

**Figure 1.20** A stone-cutter at work in Maharashtra, India (photo: S. Brzev)

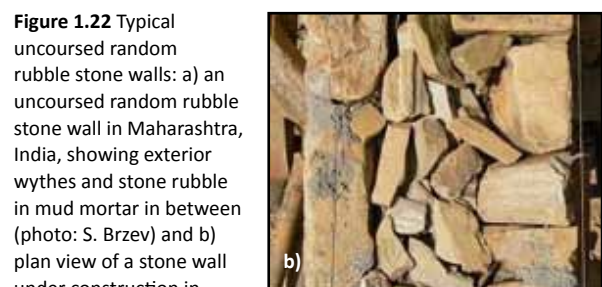

**Figure 1.21** Semi-dressed stones ready for wall construction: a) wedged stones in Maharashtra, India (photo: S. Brzev), and b) shaped stones in Pakistan (photo: T. Schacher)

## Uncoursed Random Rubble Stone Masonry

Stone used for this type of construction is of irregular shape, including small or medium-size river stones, smooth stone boulders with rounded edges, or stones from a quarry (Figures 1.22 to 1.25). Sometimes, these round stones are partially dressed to achieve a relatively regular shape (Figure 1.25). These stones are usually laid in a low-strength mortar such as mud or lime mortar. The walls consist of two wythes and the space between the wythes is filled with mud, small stones and pieces of rubble. Through-stones (long stones that extend through all wythes), which are essential for bonding the wythes and ensuring wall integrity, are usually absent. The wall thickness is usually on the order of 600 mm, but it can be excessively large—up to 2 m. In many instances, the exterior walls in the building are constructed first and the interior walls are constructed later without any connection. Rooms in these buildings are generally small and there are few small wall openings (if any).

*Rooms in buildings with uncoursed stone masonry walls are generally small and there are few wall openings.*



**Figure 1.22** Typical uncoursed random rubble stone walls: a) an uncoursed random rubble stone wall in Maharashtra, India, showing exterior wythes and stone rubble in mud mortar in between (photo: S. Brzev) and b) plan view of a stone wall under construction in Nepal (note stone rubble between the wall wythes) (photo: Smart Shelter Foundation)



**Figure 1.23** Construction of an uncoursed random rubble stone wall in Maharashtra, India (photo: S. Brzev)



**Figure 1.24** Construction of an uncoursed random rubble stone wall in Pakistan after the 2005 Kashmir earthquake (photo: M. Tomazevic)



### Uncoursed Semi-Dressed Stone Masonry

This construction type is similar to random rubble stone masonry in that there are two external wall wythes and an interior filled with rubble or dirt. However, in the case of semi-dressed stone masonry, the exterior wythes are dressed. As a result, the construction has a better appearance, although its seismic performance may not be significantly improved. Examples of uncoursed semi-dressed stone masonry from Switzerland and Pakistan are shown in Figures 1.26

**Figure 1.25** A building with uncoursed stone masonry walls in lime mortar in L'Aquila, Italy (note round stone boulders) (photo: T. Schacher)

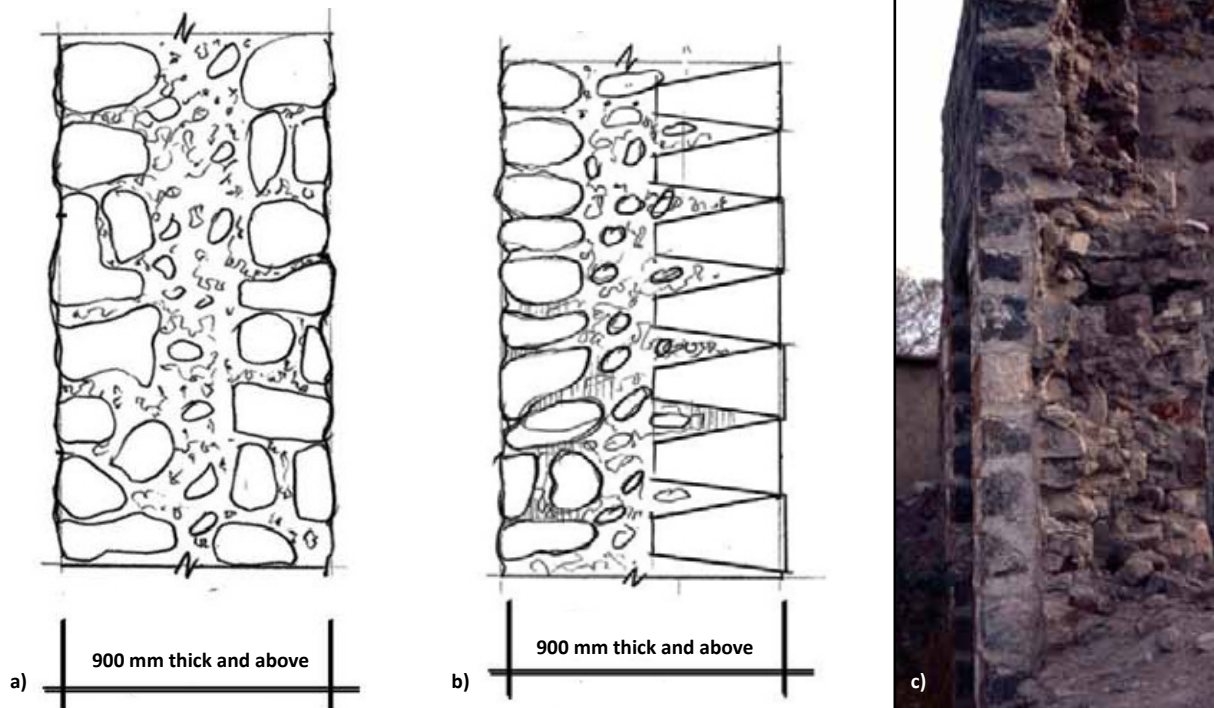

**Figure 1.26** Uncoursed semi-dressed stone masonry wall in Southern Switzerland (photo: T. Schacher)



**Figure 1.27** Stone masonry wall built using round river stone boulders with shaped exterior surfaces near Balakot, Pakistan (photo: T. Schacher)

and 1.27. Figure 1.28 shows a comparison between uncoursed random rubble stone masonry and semi-dressed stone masonry. In many parts of the world, including South Asia, it is common to build the exterior wythe of the wall using dressed or semi-dressed stone and the interior one with random rubble masonry, as shown in Figure 1.28b.



**Figure 1.28** Stone masonry walls in Maharashtra, India: a) an uncoursed random rubble stone masonry wall (source: CBRI 1994); b) a semi-dressed stone wall with an exterior wythe built using wedge-shaped dressed stone (Source: CBRI, 1994), and c) (right) an example of a semi-dressed stone wall (photo: S. Brzev)



**Figure 1.29** Stone masonry construction with timber bands in Pakistan (photo: T. Schacher)

In some regions of the world, timber or brick bands are used to enhance the wall stability in both uncoursed random rubble and semi-dressed masonry. This is a traditional practice in some parts of Nepal, India, Pakistan, Turkey, and Greece. Examples from Italy and Pakistan are shown in Figures 1.29 and 1.30. Use of timber bands (hatils) in Turkish stone masonry construction has been discussed by Erdik (1990). Figure 1.30 shows a stone masonry building in Italy with brick bands, which are expected to have an effect similar to timber bands.

*In some regions of the world, timber or brick bands are used to enhance the wall stability in both uncoursed random rubble and semi-dressed stone masonry.*

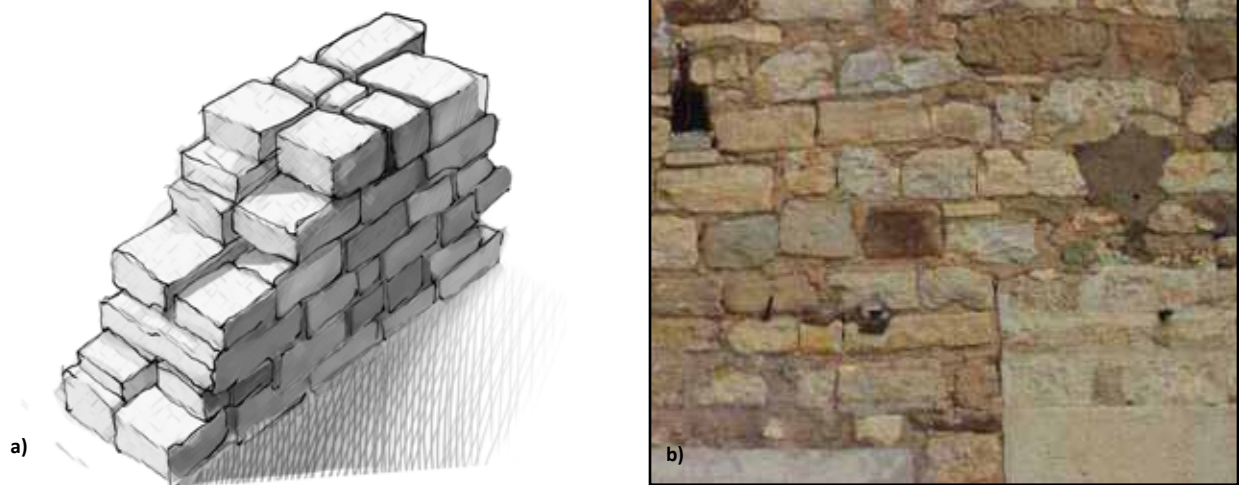

**Figure 1.30** A stone masonry wall with brick bands in L'Aquila, Italy (photo: T. Schacher)

## Dressed Stone Masonry (Ashlar Masonry)

Dressed stone masonry is constructed using stones of regular shape that look like solid blocks, as shown in Figure 1.31a. A stone with a rectangular or square face is also called ashlar, hence the name ashlar masonry (Shadmon 1996). Dressed stone masonry can be found in Europe. A few examples from Italy and Switzerland are shown in Figures 1.31 and 1.32. It should be noted that some types of stone are easier to shape than the others. For example, the widespread

use of dressed stone masonry in Italy is due to the availability of calcareous stones and tuffs (rocks formed from volcanic ash), which are relatively easy to shape. Mortar in dressed stone masonry walls is usually of poor quality, however the seismic resistance is superior compared to other types of stone masonry due to frictional forces developed at the interface between adjacent stones. The thickness of dressed stone masonry walls is less than other types of stone walls, in the range of 300 to 600 mm.



**Figure 1.31** Dressed stone masonry: a) an isometric view of a typical wall, and b) an exterior of a wall in Umbria, Italy (source: Maffei et al. 2006)



**Figure 1.32** Dressed stone masonry construction in Southern Switzerland: a) a typical building in Giornico, and b) a detail of the exterior (photos: T. Schacher)



## 2. Seismic Deficiencies and Damage Patterns

Stone masonry buildings are vulnerable to the effects of even moderate earthquakes. The excessive thickness of stone walls, often compounded by heavy floors or roof, account for the heavy weight of these buildings, thus resulting in significant inertia forces being developed during an earthquake. As a building material, stone usually has a significant strength when subjected to compression, and it is stronger than most other conventional masonry units (bricks and concrete blocks). However, when round, unshaped stones and low-strength mortar are used and artisan skills are at a low level, the resulting structures are extremely vulnerable. These unsafe practices are the result of economic constraints and lack of proper training for local artisans in countries and regions that use stone masonry.

Stone masonry buildings have shown poor performance in earthquakes, leading to significant human and economic losses. This includes performance in earthquakes in Italy, Greece, Turkey, Montenegro, Slovenia, Algeria, Iran, Pakistan, India, Nepal, and many other coun-

tries. In the 2005 Kashmir earthquake (M 7.6), over 74,000 people died in Pakistan, most of them buried under the rubble of traditional stone masonry dwellings. In India, most of the 13,800 deaths during the 2001 Bhuj earthquake (M 7.7), and more than 8,000 deaths in the 1993 Maharashtra earthquake (M 6.4), were attributed to collapses of this type of construction. Examples of devastation caused by heavy damage or the collapse of stone masonry buildings in past earthquakes are shown in Figures 2.1 to 2.4.



**Figure 2.1** Extensive damage to stone masonry buildings in the 2009 L'Aquila, Italy, earthquake (photo: T. Schacher)



**Figure 2.2** Extensive damage to stone masonry buildings in Indian earthquakes: a) the 2001 Bhuj, Gujarat, earthquake (photo: C.V.R. Murty), and b) the 1993 Maharashtra earthquake (photo: S. Brzev)



Figure 2.3 Collapse of stone masonry buildings, 2009 Bhutan earthquake (photo: K. Vatsa)

The key deficiencies of stone masonry buildings are:

- Lack of structural integrity
- Roof collapse
- Delamination of wall wythes
- Out-of-plane wall collapse
- In-plane shear cracking
- Poor quality of construction
- Foundation problems

### Lack of Structural Integrity

The seismic performance of an unreinforced masonry building depends on how well the walls are tied together and anchored to the floor and the roof (Tomazevic 1999). Consider a simple building as shown in Figure 2.5. When the walls are not connected at the intersections, each wall is expected to vibrate on its own when subjected to earthquake ground shaking (see Figure 2.5a). In this situation, the walls perpendicular to the

*In the 2005 Kashmir earthquake 74,000 people died, most buried under the rubble of traditional stone masonry dwellings.*

direction of the shaking (transverse walls) are going to experience out-of-plane vibrations and are prone to instability, and possibly collapse when anchorage to the roof and transverse walls is not adequate. Walls parallel to the direction of the shaking (shear walls) are also susceptible to damage.

When the walls are well connected, there is a rigid roof, and a horizontal ring beam (band) at the lintel level acts like a belt, the building is expected to vibrate as a monolithic box; that is a satisfactory seismic performance (see Figure 2.5b). It should be noted that a stone masonry building with a flexible roof may show good seismic performance provided that the walls are well connected and the roof maintains its integrity.



Figure 2.4 Collapsed stone masonry buildings, 2009 Bhutan earthquake (photo: K. Vatsa)

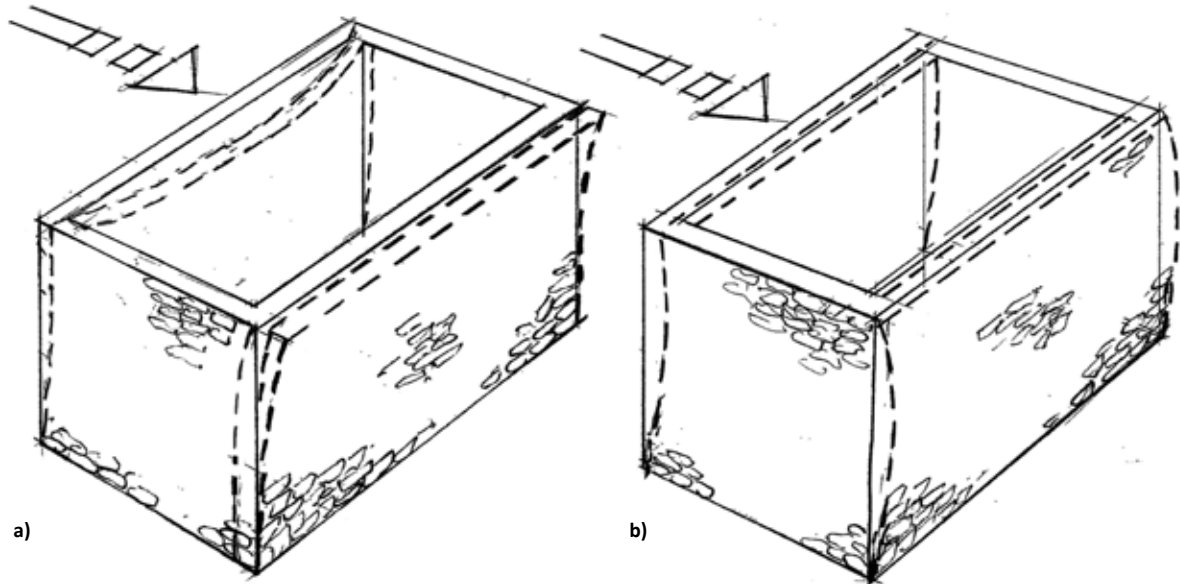
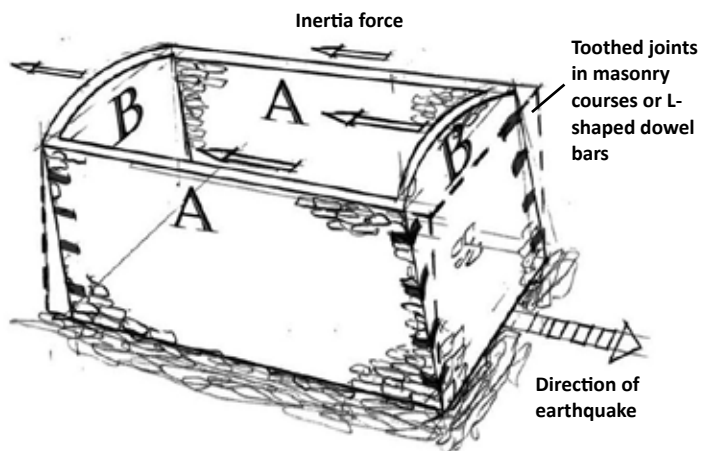

**Figure 2.5** Masonry building during earthquake shaking: a) loosely connected walls without slab at the roof level, and b) a building with well-connected walls and a roof slab (source: Tomazevic 1999)

A lack of integrity is characterized by the following damage patterns:

- Damage and/or separation of walls at intersections
- Floor and/or roof collapse from an inadequate wall-to-floor (or wall-to-roof) anchorage

**Wall B properly connected to Wall A:** Walls A (loaded in the strong direction) support Walls B (loaded in the weak direction)



**Figure 2.6** Wall connections are critical to the box-like action of a building (source: Murty 2005)

## Damage and/or Separation of Walls at Intersections

Wall intersections are particularly vulnerable to earthquake effects due to significant tensile and shear stresses developed when seismic forces are transferred from walls B (transverse walls) to walls A (shear walls), as illustrated in Figure 2.6. As a result, vertical cracks develop or separation may take place at wall intersections. These damage patterns have been observed in past earthquakes, as shown in Figures 2.7 to 2.9. In some cases, intersecting walls are built using different materials (a combination of brick or block and stone masonry), and are more susceptible to damage compared to other walls, as shown in Figure 2.37.

Adequate connections between intersecting walls are critical for ensuring the satisfactory seismic performance of a building as a whole. However, evidence from past earthquakes has shown that the presence of ring beams/bands (or alternative provisions such as ties or bandages) is very effective in enhancing structural integrity (refer to Chapters 3 and 4 for more details on bands and



**Figure 2.7** Vertical crack in a stone masonry wall due to the 1993 Maharashtra, India, earthquake (photo: S. Brzev)



**Figure 2.8** Disintegration of stone masonry walls in Greece (source: WHE Report 16)

*The evidence from past earthquakes has shown that the presence of ring beams/bands, or alternative provisions such as ties or bandages, is very effective in enhancing structural integrity.*

bandages). An example of a stone building with an RC roof band that remained undamaged in the 2005 Kashmir earthquake in Pakistan is shown in Figure 2.10. Figure 2.11 shows a building with an RC lintel band that showed good performance in the same earthquake.

After the 2005 Kashmir earthquake, a significant research program related to evaluating and improving the seismic resistance of stone masonry buildings was undertaken at the NWFP University of Engineering and Technology, Peshawar, Pakistan (Ali et al. 2010). Three one-third scale models of a single-story stone masonry house were tested on a shake-table. One of the models had semi-dressed stone masonry walls built in cement mortar and an RC roof slab (SM1). The other model, named SM2, had uncoursed rubble stone masonry walls in mud mortar and a timber roof with a mud overlay. Vertical RC members were also provided at the corners of this model. The third model (SM3) was similar to SM2, but additional horizontal bands were provided at sill, lintel, and roof levels. The models were subjected to the same earthquake record, but they showed substantially different responses. Model SM1 collapsed at a significantly lower shaking intensity, and lost integrity once the separation of the roof slabs and the walls took place at a peak ground acceleration (PGA) of 0.22 g. The walls demonstrated a brittle response and ultimately failed. The presence of vertical RC members at the corners in model SM2 caused a slight increase in strength as well as displacement capacity. However, they did



**Figure 2.9** Damage at a wall intersection of a single-story stone masonry building in the 2009 Padang, Indonesia, earthquake (note absence of bands at lintel and roof levels) (source: Bothara et al. 2010)



**Figure 2.10** A stone masonry building in Muzzaffarabad was undamaged in the 2005 Kashmir, Pakistan, earthquake; this was attributed to the presence of an RC band at the eaves level (photo: J. Bothara)



**Figure 2.11** A stone masonry building with an RC lintel band that survived the 2005 Kashmir earthquake in Pakistan: a) the building suffered only moderate damage in the top portion, and b) separation at the wall intersection took place in spite of the band (note inadequate anchorage of the band reinforcement) (photos: Builders Without Borders)

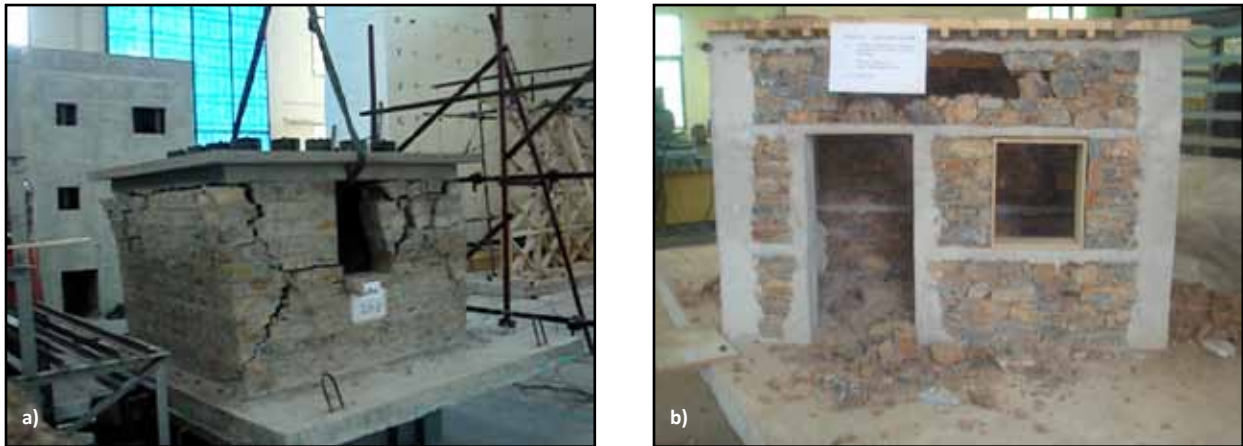

**Figure 2.12** Damaged models at the end of the test: a) failure of model SM1, and b) model SM3 at the end of the experiment (source: Ali et al. 2010)

not improve the overall capacity of the structure, as the model faced moderate damages at a PGA of 0.16 g and major damages at a PGA of 0.26 g. Model SM3 showed an excellent response, and maintained its integrity until the base acceleration (PGA) of 0.27 g was reached. Model SM1, with semi-dressed stone walls in cement mortar, showed worse performance than model SM2, which had uncoursed rubble walls in mud mortar. It was concluded that bands provided at several levels are effective in maintaining the integrity of a building because these elements divide the walls into smaller portions. Figure 2.12 shows models SM1 and SM3 at the end of the test.

### Inadequate Wall-to-Floor and Wall-to-Roof Anchorages

Reports from many past earthquakes have confirmed that wall-to-floor and wall-to-roof anchorages are critical for ensuring the integrity of a building and preventing floor and roof collapse. When an anchorage is not adequate, the walls perpendicular to the direction of the earthquake shaking move away from the floors and roof, and might topple outward; this is known as “out-of-plane” collapse. Figure 2.13 illustrates the consequences of inadequate wall-to-roof anchorage.

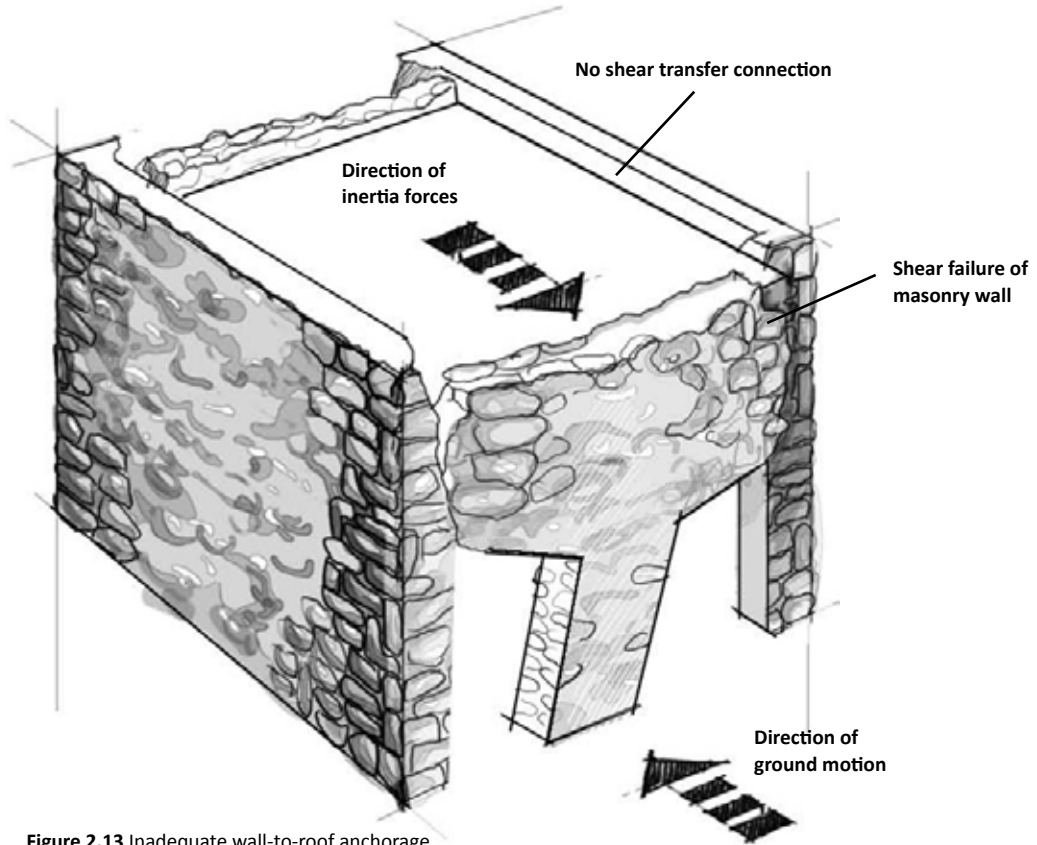

Figure 2.13 Inadequate wall-to-roof anchorage

In the Anjar area of Gujarat, India, which was affected by the 2001 Bhuj earthquake, buildings are characterized by thick stone masonry walls (thickness around 750 mm) built in sandstone and lime mortar (Jain et al. 2002). In this area, the traditional buildings have timber roofs with rafters spanning two walls in a room, instead of spanning the full length of the building. As a result, the floor in each room acted as an independent system, and had a tendency to pull apart from the other floors during the strong ground shaking. This caused a partial or total collapse of many stone masonry buildings in the area (Figure 2.14).



Figure 2.14 Roof deficiencies in the area affected by the 2001 Bhuj, India, earthquake: a) discontinuous rafters over interior walls, and b) inadequate wall-to-floor connections caused the severe building damage (photos: C.V.R. Murty)

Evidence from past earthquakes has shown that buildings with good floor-wall and roof-wall anchorages are able to resist earthquake effects and maintain integrity without collapse (Figures 2.15 and 2.16).

Hipped roofs made of timber or light metal are common in areas affected by the 2005 Kashmir, Pakistan, earth-



**Figure 2.15** A building with horizontal wall anchors at the floor level survived the 2009 L'Aquila, Italy, earthquake (photos: T. Schacher)



**Figure 2.16** A building with roof-to-wall anchors survived the 2009 L'Aquila, Italy, earthquake (photos: T. Schacher)

quake. These buildings have a few important seismic deficiencies, such as an absence of effective ties or ring beams (bands) at the eaves level (beneath the roof), inadequate wall-to-roof anchorage, and an absence of through-stones in the walls. Buildings of this type showed poor performance in the earthquake due to the collapse of stone masonry

walls, as shown in Figure 2.17. It should be noted that the seismic performance of hipped roofs in the earthquake was excellent in terms of maintaining their integrity and shape. After the earthquake, people were able to lift the roof of their collapsed house and rebuild the walls (Bothara and Hıçyılmaz 2008).



**Figure 2.17** Collapse of stone masonry buildings with hipped roofs in the 2005 Kashmir, Pakistan, earthquake (source: Bothara and Hıçyılmaz 2008)

## Roof Collapse

Roof collapse is one of the major causes of fatalities in masonry buildings during earthquakes, and it can take place when either the walls lose the ability to resist gravity loads and collapse, or when the roof structure collapses (e.g. timber post-and-beam construction) (Coburn 1987). Roof collapse is often caused by inadequate wall-to-roof anchorage. The roof structure can simply “walk away” from the walls and cave into the building. Roof collapse can also be caused by the collapse of supporting walls, as shown in Figure 2.18.

Some stone masonry buildings have heavy roofs that contribute to their seismic vulnerability. Heavy RC roof slabs contributed to the collapse of buildings in the 2005 Kashmir earthquake (Figure 2.18a). Traditional buildings in the Marathwada area of Maharashtra, India, affected by the 1993 earthquake, were characterized by a timber plank-and-joist roof supporting

a 500 to 800 mm thick mud overlay (GOM 1998). The roofs were supported by interior timber frames (called khands) which were not connected to the walls, as shown in Figure 2.19. In the earthquake, heavy roof mass caused lateral swaying of the frames, which pushed the stone walls outward and caused their collapse.

## Delamination of Wall Wythes

Stone masonry walls constructed of two exterior wythes are prone to delamination. As discussed in Chapter 1, the space between the wythes is usually filled with small stones and pieces of rubble bonded together with mud mortar. These wythes are usually constructed using large stone boulders (either round stones or partially dressed stones). The large wall thickness is required to ensure the thermal comfort and/or personal security of the inhabitants.



**Figure 2.18** Collapse of roof structures due to the loss of gravity load-bearing capacity of stone walls in the 2005 Kashmir, Pakistan, earthquake: a) reinforced concrete roof, and b) timber and steel roof (photos: M. Tomazevic)



**Figure 2.19** Wall collapse in the 1993 Maharashtra, India, earthquake. Stone masonry buildings had timber roofs with heavy mud overlays (photo: S. Brzev)

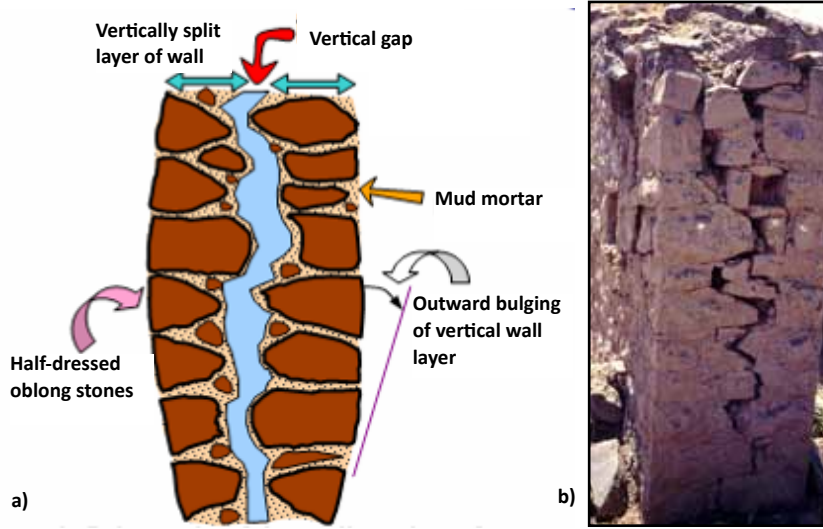

**Figure 2.20** Delamination of stone masonry walls: a) delamination in progress (source: Murty 2005), and b) (right) delamination of wall wythes due to the 1993 Maharashtra, India, earthquake (photo: S. Brzev)

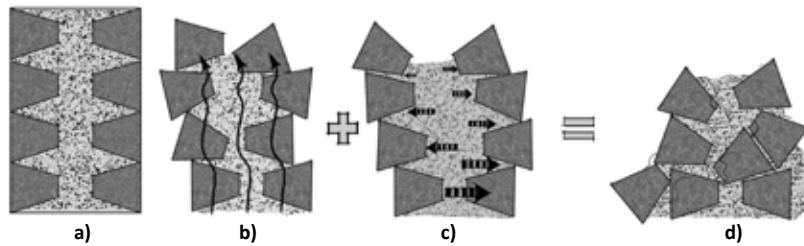

**Figure 2.21** Delamination of stone masonry walls: a) two-wythe stone wall with a rubble core; b) stones are displaced due to vibrations; c) internal lateral pressure due to rubble fill increases, and d) the wall collapses (source: Meyer et al. 2007)

Delamination takes place when vertical wall layers (wythes) bulge and collapse outward due to earthquake ground shaking, as shown in Figure 2.20. One of the causes of delamination is the absence of through-stones, that is, long stones which tie the wythes together. Other factors influencing delamination include intensity of ground shaking, shape of stone (round, irregular, or regular), and the magnitude of the gravity load.

A detailed experimental and analytical research study on the delamination of stone masonry walls was performed by Meyer et al. (2007). According to the study, delamination is triggered by high-frequency vibrations that cause inter-stone vibrations. This results in a reduction of frictional forces that hold the stones together, particularly when wedge-

shaped stones are used. Another possible cause of delamination is an increase in internal lateral pressure from the soil or rubble core of the wall, which pushes the wall wythes outward. The delamination process observed during the testing is illustrated in Figure 2.21.

Delamination of the wythes in stone masonry walls has been observed in several earthquakes around the world, as shown in Figures 2.22 and 2.23. Delamination is usually initiated in the upper portion of the wall, and the appearance of the damaged wall is as if the exterior wythe has been peeled off. It was reported after the 2002 Molise earthquake in Italy that “spreading (delamination) damage in stone masonry walls begins at the top of the building, where the lack of overburden weight allows the masonry to vibrate apart. The stability of the wall can be most at risk when the masonry units vary in size and are laid with a minimum of horizontal bedding” (Decanini et al. 2004).



**Figure 2.22** Delamination of a stone masonry wall in the 2000 Beni-Ouartilane, Algeria, earthquake (photo: M. Farsi)

The chances of delamination can be considerably reduced if wall wythes are “stitched” by means of through-stones (also known as “bond stones” or “headers”). An experimental study by Meyer et al. (2007) demonstrated the effectiveness of through-stones in enhancing the out-of-plane seismic performance of stone walls. The results showed that a regular untied wall specimen collapsed at an acceleration of 0.19 g, while a similar specimen with two through-stones for a given wall surface area failed at an acceleration of 0.32 g, and the specimen with four through-stones failed at an acceleration of 0.45 g. The installation of through-stones in new and existing stone masonry walls is discussed in Chapters 3 and 4, respectively.



Figure 2.23 Delamination was a common damage pattern observed in the 1993 Maharashtra, India, earthquake (photos: S. Brzev)

## Out-of-Plane Wall Collapse

Out-of-plane wall collapse is one of the major causes of destruction in stone masonry buildings, particularly in buildings with flexible floors and roofs. As discussed earlier in this chapter, overall building integrity is critical for the satisfactory seismic performance of stone masonry buildings. The connections between structural component are important for maintaining building integrity, as discussed in Chapter 3. Integrity is absent or inadequate when the walls are not connected at their intersections and there are no ties or ring beams at the floor and roof levels. As a result, each wall vibrates on its own when subjected to earthquake ground shaking and is therefore likely to collapse. In multi-story buildings, this type of collapse usually takes place at the top floor level due to the significant earthquake accelerations there (Figures 2.24 and 2.25).

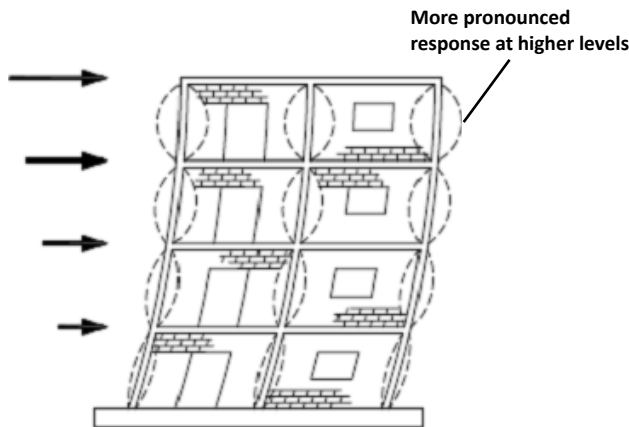
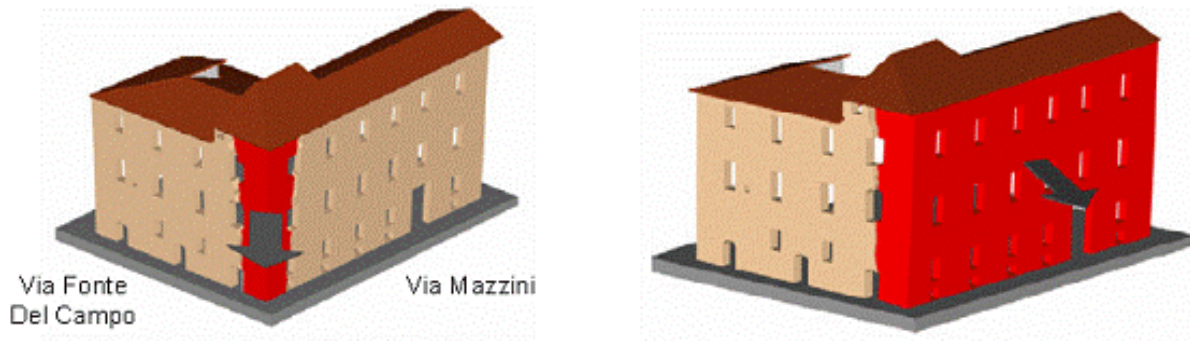

Figure 2.24 Out-of-plane vibrations of stone masonry walls are most pronounced at the top floor level (source: Tomazevic 1999)



Figure 2.25 Out-of-plane collapse at the top floor of a stone masonry building in the 2003 Boumerdes earthquake in Algeria (photo: M. Farsi)



**Figure 2.26** Rendered images of a building damaged in the 2002 Molise (Italy) earthquake: a) the stone masonry construction is damaged at the corner resulting in a loss of gravity support; b) a façade falls away from the floor and roof diaphragms (source: Maffei et al. 2006)

Depending on the intensity of earthquake ground shaking, this failure mechanism is characterized either by vertical cracks developed at the wall intersections, or by tilting and collapse of an entire wall. This collapse mechanism was observed after the 2002 Molise, Italy, earthquake (Maffei et al. 2006) (Figure 2.26).

When cross walls parallel to the direction of earthquake shaking are far apart, the central areas of long walls are subjected to significant out-of-plane vibrations and may collapse (Figure 2.27). The inadequacy of connections between the cross walls and long walls is one of the key factors influencing out-of-plane wall collapse. When connections are inadequate, long walls are more susceptible to the effects of out-of-plane vibrations and the chances of collapse are higher (Figure 2.28).



**Figure 2.27** Out-of-plane collapse of a long wall in the 1988 East Nepal earthquake (photo: TAEC Consult, Nepal)

Out-of-plane wall collapses were reported in the area affected by the 2009 Padang earthquake in Indonesia. The two-story buildings shown in Figure 2.29 had light metal roofing supported by timber trusses. The floors were inadequately connected to the walls. Stone masonry walls were 250 mm thick and relatively slender. The walls were constructed using 100 to 120 mm diameter round or angular stones in lime/sand mortar. The walls collapsed due to the absence of floor and roof anchorages and bands (refer to Chapter 3).

Out-of-plane wall collapse is common in buildings with flexible roofs and floors, and where wall-to-roof connections are inadequate, as shown in Figure 2.30.



**Figure 2.28** Out-of-plane collapse of two parallel walls, NWFP Pakistan (photo: SDC)



Figure 2.29 (left and above) Out-of-plane collapse of stone masonry walls in the 2009 Padang, Indonesia, earthquake (source: Bothara et al. 2010)



Figure 2.30 Out-of-plane collapse of stone masonry walls in buildings with flexible roofs and inadequate wall-to-roof connections: a) the 2005 Kashmir, Pakistan, earthquake (photo: M. Tomazevic); b) the 2003 Boumerdes, Algeria, earthquake (photo: M. Farsi)



*Adequate connections between cross walls and long walls are critical for preventing out-of-plane wall collapse.*



**Figure 2.31** A tall gable wall in Nepal that is at risk due to the absence of a roof connection (photo: Smart Shelter Foundation)

Buildings with pitched roofs have gable walls. These are taller than other walls and tend to vibrate as free-standing cantilevers during earthquakes, unless they are tied to the roof structure. These walls are often inadequately connected to the roof, as shown in Figure 2.31. Out-of-plane collapse of gable walls is often reported after earthquakes. Several stone masonry gable walls collapsed in the 2010 and 2011 New Zealand earthquakes, as shown in Figure 2.32.

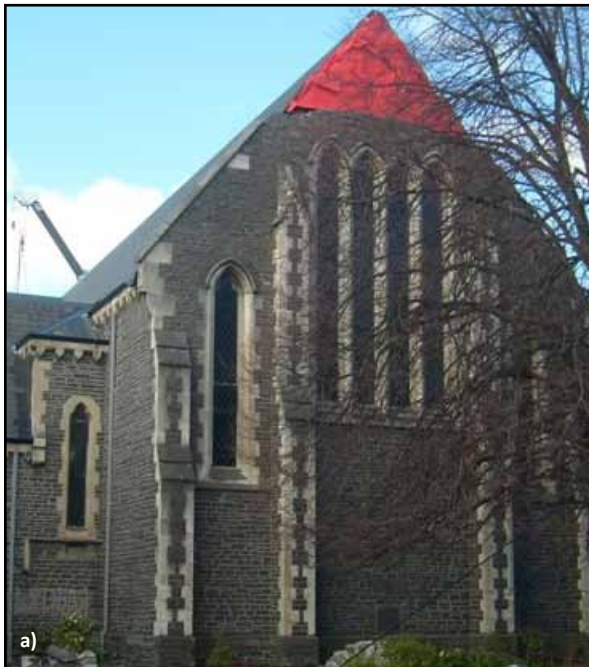

## In-Plane Shear Cracking

Damage to stone masonry walls due to in-plane seismic effects (in the direction of the wall length) is less common than damage due to out-of-plane seismic effects. Vulnerability is mainly caused by the manner in which the walls are constructed, often using irregular stones and weak mortar.

A typical masonry wall consists of piers between openings, plus a portion below openings (sill masonry) and above openings (spandrel masonry), as shown in Figure 2.33a. When subjected to in-plane earthquake shaking, masonry walls demonstrate either rocking or diagonal cracking. Rocking is illustrated in Figure 2.33b, and is characterized by the rotation of an entire pier, which results in the crushing of pier end zones. Alternatively, masonry piers subjected to shear forces can experience diagonal shear cracking (also known as X-cracking), as shown in Figure 2.33c. Diagonal cracks develop when tensile stresses in the pier exceed the masonry tensile strength, which is inherently very low. This type of damage is typically observed in the bottom story of a building.

Several factors influence the in-plane failure mechanism of stone masonry buildings, including pier dimensions, wall thickness, building height, and masonry shear strength. Rocking behavior is more desirable than diagonal shear cracking. In-plane wall damage patterns observed in past earthquakes are illustrated in Figure 2.34.



**Figure 2.32** Collapse of stone masonry gable walls in New Zealand earthquakes: a) a partial collapse in the 2010 Darfield earthquake, and b) total collapse of the same building in the 2011 Christchurch earthquake (photos: J. Bothara)

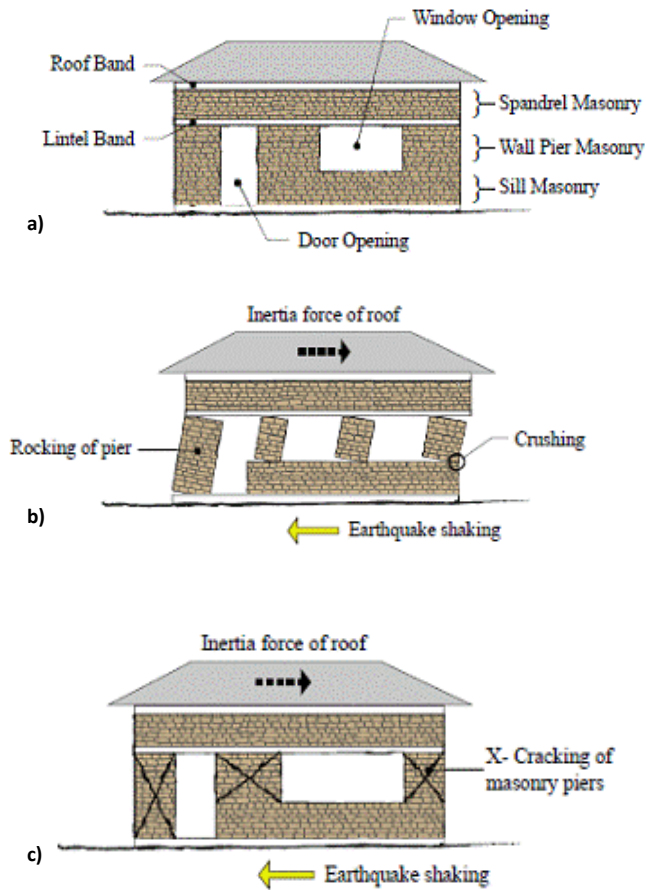

**Figure 2.33** In-plane damage of stone masonry walls: a) typical wall with openings; b) rocking failure, and c) diagonal shear cracking (adapted from: Murty 2005)

## Poor Quality of Construction

Reports from past earthquakes confirm that the use of low quality building materials and poor construction practices often result in significant earthquake damage or destruction. For example, evidence from the 2001 Bhuj earthquake in India indicates that semi-dressed/dressed stone masonry in cement mortar generally suffered less damage than random rubble stone masonry in mud mortar (Jain et al. 2002). During earthquake shaking, irregularly placed stones tend to move out (displace) from the wall and cause localized damage or even collapse in extreme cases, as shown in Figure 2.35. When the stone surface is not clean, or smooth river boulders are used, the bond between stones and mortar can be weak. Poor bond strength is generally not a problem, except under earthquake conditions. During lateral movement in the structure the mortar crumbles as the stones move and the walls lose integrity and may suffer damage or collapse.



**Figure 2.34** Shear failure in stone masonry walls: a) shear cracks initiated at the corners of openings in the 2005 Kashmir, Pakistan, earthquake (Photo: Bothara and Hiçyılmaz, 2008), and b) shear cracking in a stone masonry pier damaged by the same earthquake (photo: Builders Without Borders)



**Figure 2.35a** Localized wall failure caused by irregular stones (source: WHE Report 74)

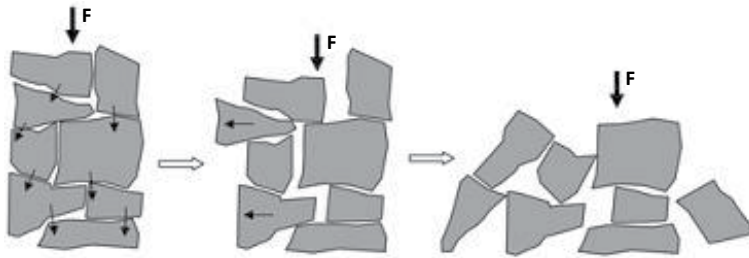

**Figure 2.35b** Detail of wall failure caused by irregular stones (source: Bothara and Hiçyılmaz 2008)

When the mortar used for construction is made of mud instead of cement and/or lime, the mortar becomes the weak link and prevents a proper bond between the mortar and the stones. In some cases, mud mortar is excessively thick (Figure 2.36). Even when cement mortar is used, minimum quality standards (as discussed in Chapter 3) are often not met during construction.

Another problematic construction practice is the use of more than one kind of material for wall construction, for example, stones and brick. Because of the differences in size and shape of materials, the bonds between orthogonal walls are reduced. Figure 2.37 shows a building in which one wall is constructed of brick masonry and the other of stone masonry. The use of mixed structural materials and systems results in dissimilar strength and stiffness in the different parts of a building. This can cause torsional effects once damage begins to accrue in the building. It is acceptable to mix materials provided that only one material is used for each story. The stronger materials should be used for the ground floor wall construction.

## Foundation Problems

Foundations are not considered to be critical in the seismic performance of stone masonry buildings. However, it was reported after the 2005 Kashmir, Pakistan, earthquake that buildings on foundations of adequate size suffered less damage than those supported by shallow foundations. Foundation soils may be prone to instability, in the form of soil spreading or landslides (Figure 2.38). Buildings in hilly areas were most affected by the 2005 Kashmir earthquake due to soil movement.

Traditional foundations in non-engineered buildings are often very shallow and inadequate for soft soil conditions. For example, in the area affected by the 1993 Maharashtra earthquake in India, foundation depth was on the order of 600 mm, which is significantly less than required for the buildings located in the region where expansive black cotton soil is common. As a result, cracking in the walls due to foundation movement was common even before the earthquake.



**Figure 2.36** A stone masonry wall with thick mud mortar (thickness on the order of 80 mm) in the area affected by the 2001 Bhuj, India, earthquake (photo: J. Arlekar)



**Figure 2.37** Vertical cracking at a wall intersection due to the 2005 Kashmir, Pakistan, earthquake due to absence of connection between the intersecting walls, a stone masonry and a brick-masonry wall (source: Bothara and Hiçyılmaz 2008)



**Figure 2.38** Soil spreading in the 2005 Kashmir, Pakistan, earthquake - note wide cracks in the walls (source: Bothara and Hiçyılmaz 2008)



### 3. Stone Masonry Construction with Improved Earthquake Performance

Damage is expected during major ground shaking even in buildings designed and constructed according to the latest building codes. However, even in severe earthquake shaking, buildings should not collapse, threatening the life safety of the occupants. It is usually not economically viable to construct a stone masonry building to resist a strong earthquake without significant damage. However, the provision of seismic measures during construction is critical for limiting the extent of damage and preventing collapse. This chapter provides important considerations to be taken into account before and during the construction of a new stone masonry house to ensure its enhanced seismic performance.

#### Building Site

The first step in constructing a new building should involve careful selection and review of possible building sites. The site should provide a stable and firm base for the building. It is best to build on areas that have firm soil or rock underneath the topsoil. Soft soils can amplify building movement due to earthquakes, cause excessive settlement, and require more elaborate foundations. The selected building site should have a consistent soil type across the entire building area. Variations in base soil types can cause unequal settlement problems and uneven support conditions that could jeopardize integrity of the building. The key considerations related to the selection of a suitable building site are discussed below.

Buildings should not be constructed near or on steep slopes due to the high risk of damage (Figure 3.1). Flat sites are preferable; they reduce the need for excessive earthworks prior to construction and help ensure a simple building design and construction process. Special precautions should be taken to avoid

soil instability, and consequent destruction of the building if it is constructed on sloping ground; this can be achieved by following the procedure illustrated in Figure 3.2.

Under normal conditions, the slopes may be stable, but an earthquake could trigger landslides or rock-falls, which can cause a partial or complete building collapse (Figures 3.3). Retaining walls, rock barriers and green barriers can provide protection. A simple indication of slope instability is the presence of inclined standing trees.

The site should be located away from riverbanks and large trees. Also, construction of buildings at sites with predominantly loose sand, uncompacted soil, or soft clay should be avoided. However, when that is not possible, sufficient drainage should be provided and the ground level of the building should be raised by compacted earth forming a plinth. When a building has to be constructed on fill, the foundations should be deep enough to rest on the firm ground surface below the fill. Pile foundations are suitable in some cases.



**Figure 3.1** A collapsed building on a steep slope after the 2005 Kashmir earthquake, Pakistan (source: Bothara and Hıçyılmaz 2008)

1. Start the retaining wall 3 ft below vegetable soil and prepare a base half as wide as the finished wall height.
2. Maximum height of a retaining wall should not exceed 8 ft. The lower the wall, the stronger it will be.
3. Incline the front of the wall in a ratio 1:5. That is, for every 5 ft of height, go 1 ft back.
4. Incline the stones at a right angle to the front.
5. Place as many 'through-stones' as possible, but at least every 2 ft along the height and length of the wall.
6. If mortar is used, leave 4"x4" drainage holes in the lower part of the wall, every 2 ft.
7. Instead of making one high wall, subdivide it into several lower walls, stepping back each time the same distance as the height of the lower wall.
8. Keep the building away from the retaining walls.
  - On the lower side at least the same distance as the height of the wall.
  - On the upper side at least 3 ft from the retaining wall.
9. Curved retaining walls are stronger.

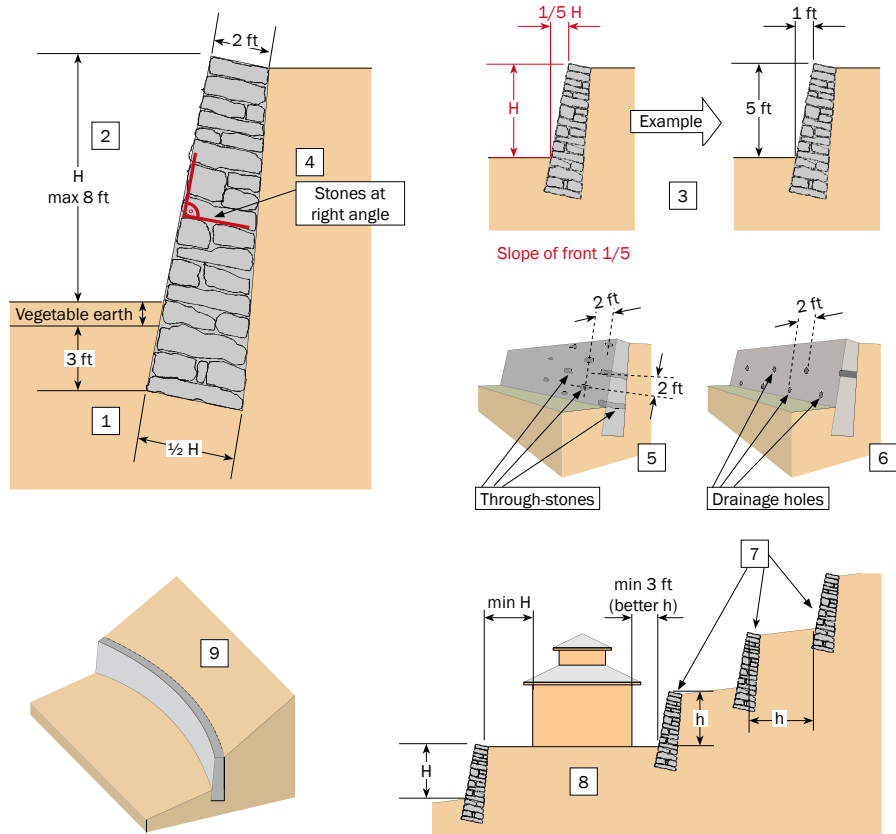

Figure 3.2 Special provisions for building construction on a steep slope (source: Schacher 2009)

## Building Configuration

### Building Plan

Building plans should be regular, simple, and symmetrical. Buildings with square, rectangular or circular plans have shown better seismic performance than buildings with irregular plans in past earthquakes.

Buildings with T-, L-, or C-shaped plans are prone to twisting, localized damage or even collapse and disintegration at wall intersections. When the proposed plan of a building is irregular, it should be divided into smaller blocks of regular plans (Figure 3.4).

Long and narrow buildings appear to suffer more extensive damage during earthquakes. Without the support of cross walls, long walls are very flexible and may collapse during ground shaking. When a building is longer than three times its width, it should be divided into smaller blocks with sufficient

gaps between them; these blocks could be built on the same foundation (Figure 3.4). Another approach is to construct buttresses or interior cross walls (these will be discussed later in this chapter).



Figure 3.3 A building damaged by a landslide in the 2005 Kashmir, Pakistan, earthquake (source: Bothara and Hıçyılmaz 2008)

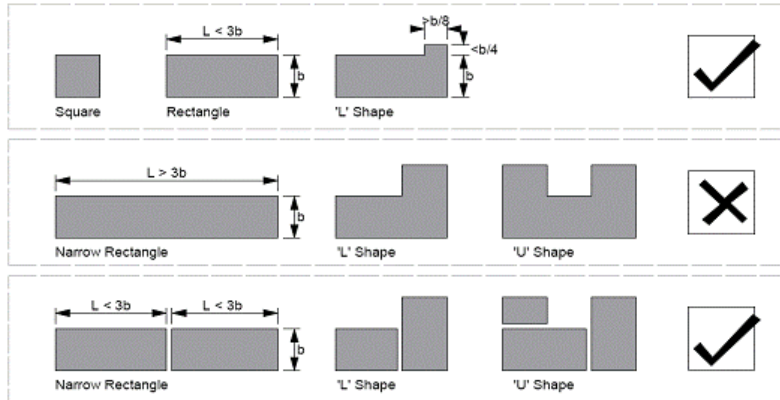

Figure 3.4 Building configurations: DOs and DON'Ts (adapted from: IAEE 2004)

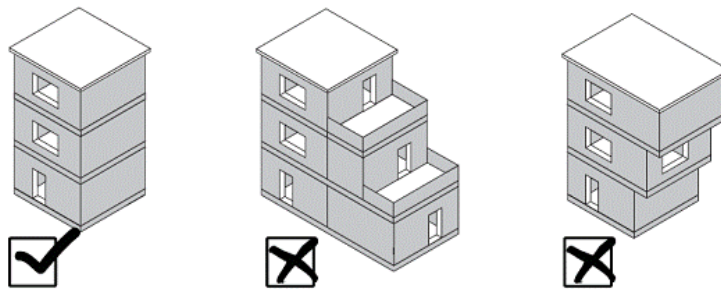

Figure 3.5 Building irregularity in vertical direction: regular buildings are recommended, and buildings with setbacks or overhangs are not.

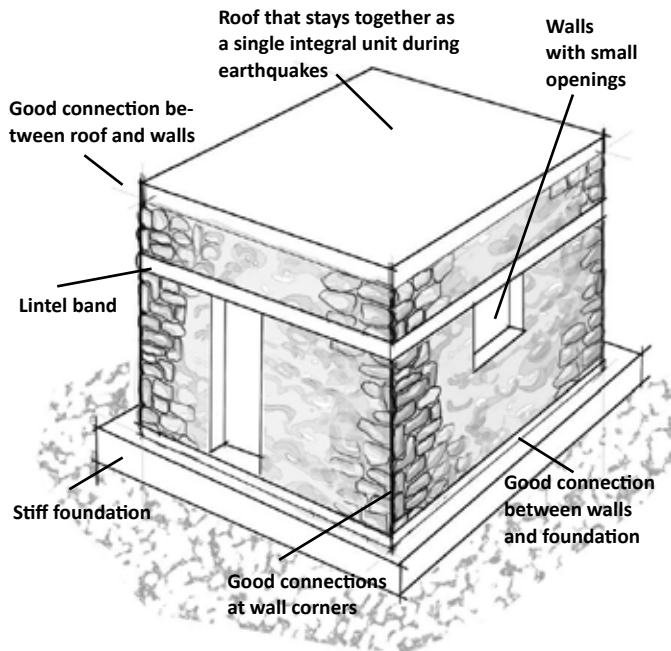

Figure 3.6 Key requirements for ensuring box action in a stone masonry building (adapted from: Murty 2005)

## Building Elevation

A stone masonry building should be as regular as possible up its height (Figure 3.5). Setbacks are not recommended. However, if they cannot be avoided, a load-bearing wall should be provided beneath each wall in the upper story.

## Building Height

Non-engineered stone masonry buildings with walls built using cement mortar should be limited to two stories in high seismic zones, and three stories in moderate to low seismic zones. However, when mud mortar is used for wall construction, building height should be limited to one story in high seismic zones, and two stories in moderate and low seismic zones. The definition of seismic zones is country-specific and is usually prescribed by national building codes.

Keep the height of stone masonry buildings to a minimum. Taller buildings are heavier than short ones, and as a result they attract larger earthquake forces and have a greater chance of suffering damage due to earthquake shaking.

## Structural Integrity (Box Action)

Past earthquakes have shown that damage to unreinforced masonry buildings is significantly reduced when building components are well connected and the building vibrates like a monolithic box, as discussed in Chapter 2. In many cases, unreinforced masonry buildings have flexible floors (in-plane), so there is a need to provide additional elements to tie the walls together and ensure acceptable seismic performance. Structural integrity of a building can be achieved by developing a box action by ensuring good connections between all building components—foundations, walls, floors, and roof. Key requirements for the structural integrity in a masonry building are illustrated in Figure 3.6. A ring beam (band) at lintel level is one of the critical provisions for ensuring structural integrity.

## Seismic Bands (Ring Beams)

### Background

A seismic band is the most critical earthquake-resistant provision in a stone masonry building. Usually provided at lintel, floor, and/or roof level in a building, the band acts like a ring or belt, as shown in Figure 3.7. Seismic bands are constructed using either reinforced concrete (RC) or timber. Proper placement and continuity of bands and proper use of materials and workmanship are essential for their effectiveness.

Seismic bands hold the walls together and ensure integral box action of an entire building. Also, a lintel band reduces the effective wall height. As a result,

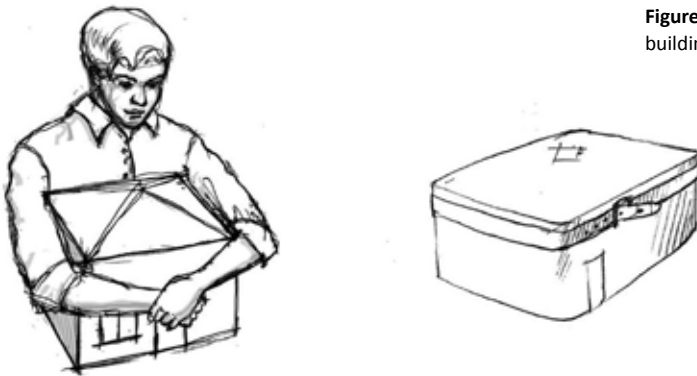

Figure 3.7 A seismic band acts like a belt (adapted from: GOM 1994)

bending stresses in the walls due to out-of-plane earthquake effects are reduced and the chances of wall delamination are diminished.

During earthquake shaking, a band undergoes bending and pulling actions, as shown in Figure 3.8. A portion of the band perpendicular to the direction of earthquake shaking is subjected to bending, while the remaining portion is in tension.

Seismic bands can be provided at plinth, lintel, floor, and roof levels (Figure 3.9). In some cases, a lintel band is combined with a floor or roof band. An RC plinth band should be provided atop the foundation when strip footings are made of unreinforced masonry and the soil is either soft or uneven in its properties (as discussed later in this chapter).

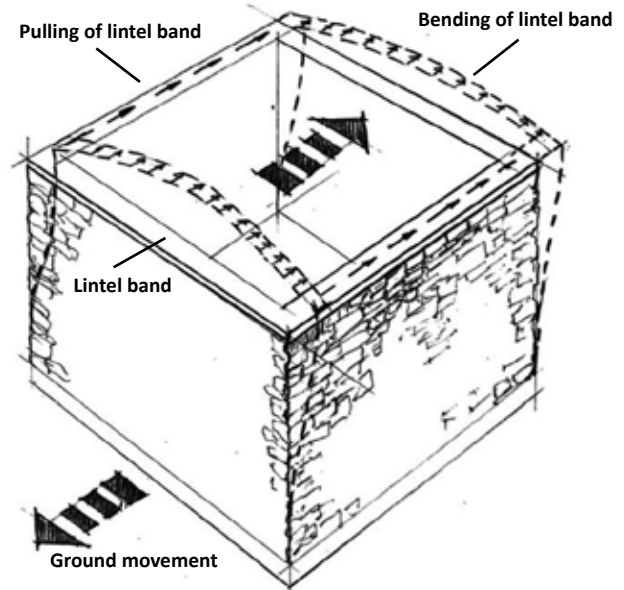

Figure 3.8 Pulling and bending of a lintel band in a stone masonry building (adapted from: Murty 2005)

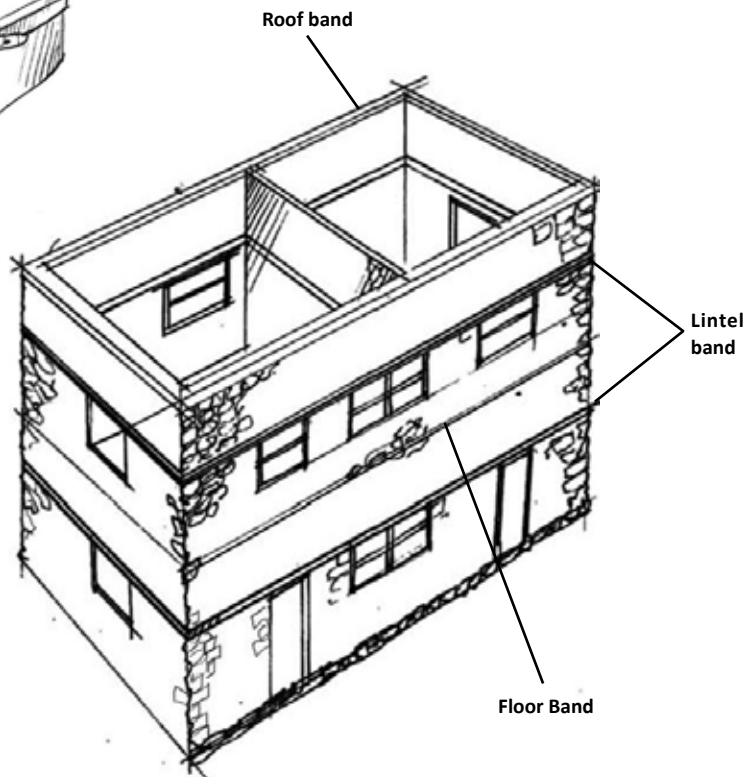

Figure 3.9 Locations of seismic bands in a stone masonry building (roof omitted for clarity) (adapted from: UNCRD 2003)

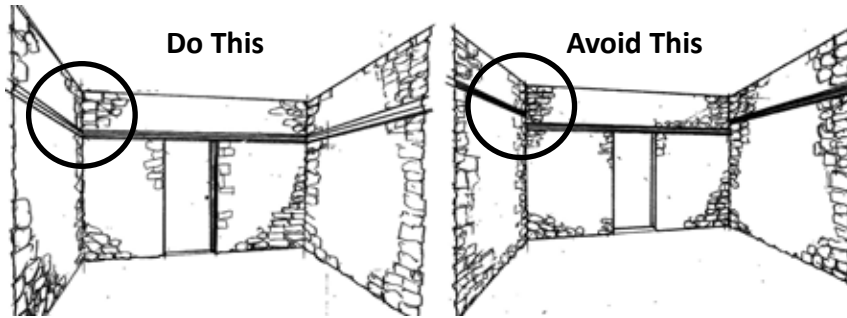

Figure 3.10 Seismic bands should always be continuous; an offset in elevation is not acceptable (adapted from: GOM 1998)

*Seismic bands must be continuous, like a loop or a belt.*

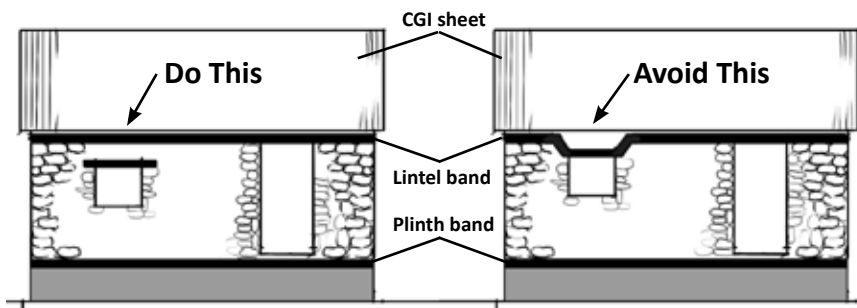

Figure 3.11 RC seismic bands should always remain level without any dips or changes in height (adapted from: GOM 1998)

Seismic bands must be continuous (like a loop or a belt), otherwise they are inefficient. Some examples of undesirable discontinuities in lintel band construction are illustrated in Figures 3.10 and 3.11.

Seismic bands are required at lintel and floor levels, when the floor and roof structures are flexible, the vertical distance between lintel and floor level is more than 400 mm, or when the total story height exceeds 2.5 m (the same is true of roof bands as well). Otherwise, the provision of a lintel band is sufficient. A floor/roof band is not required in buildings with RC floor/roof structures. In such cases, the slab itself ties the walls together.

Lintel beams (commonly known as lintels) are required atop all the openings in a wall. However, if a band is provided at the lintel level, a lintel beam can be cast as an integral part of the lintel band to minimize construction costs, as illustrated in Figure 3.12. Details for combining a lintel and floor/roof band are shown in Figure 3.13. The band must be continuously reinforced at the wall intersections, as shown in Figure 3.14.

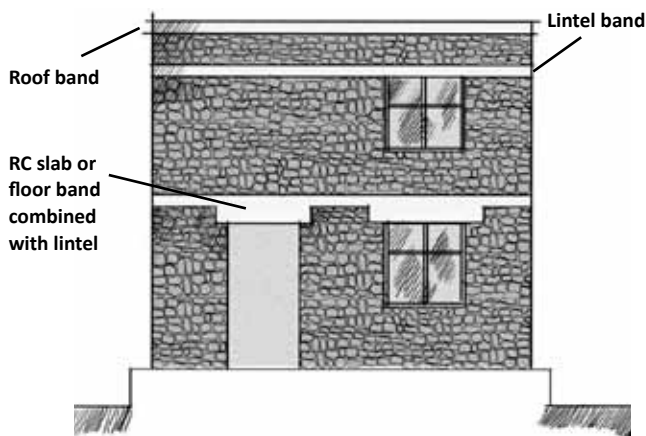

Figure 3.12 Merging RC floor and lintel bands

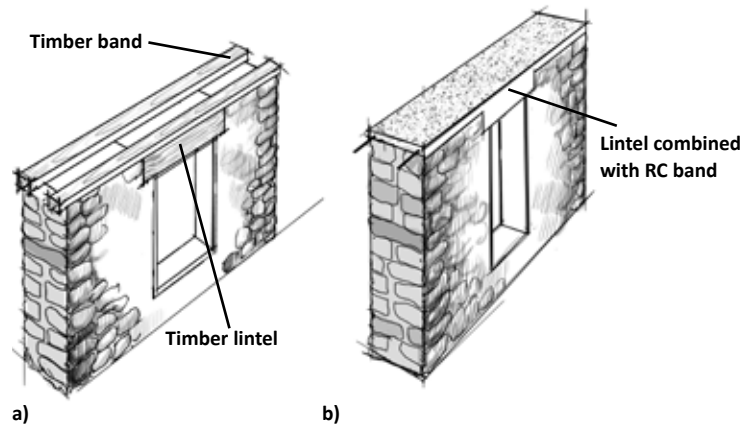

Figure 3.13 Combining floor/roof and lintel band: a) timber band, and b) RC band

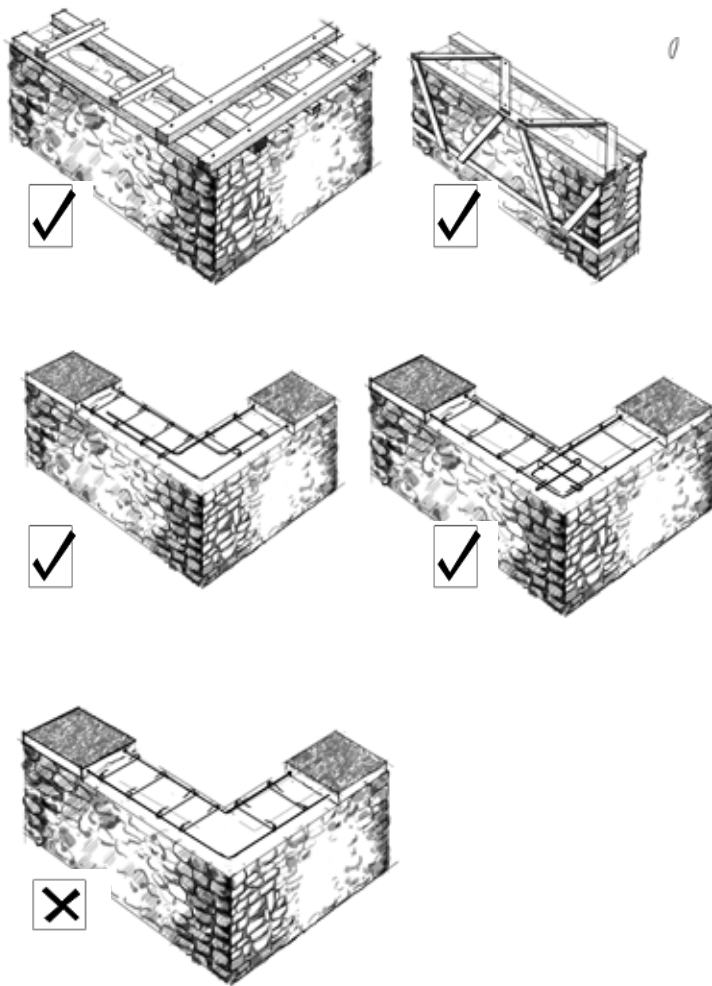

Figure 3.14 Recommended detailing of timber and RC bands (adapted from: T. Schacher and C.V.R. Murty)

### Reinforced concrete bands

RC bands are generally a better choice than timber bands due to their low maintenance, long service life, and improved integrity with the stone, provided the concrete is properly mixed, placed, and compacted. Stone masonry buildings with RC bands performed well in past earthquakes, such as the 2005 Kashmir, Pakistan, earthquake, as discussed in Chapter 2, and were used in post-earthquake rebuilding efforts in India, as shown in Figure 3.15.

The required number and size of reinforcing bars in RC bands depends on the room span (distance between adjacent cross walls), the importance of

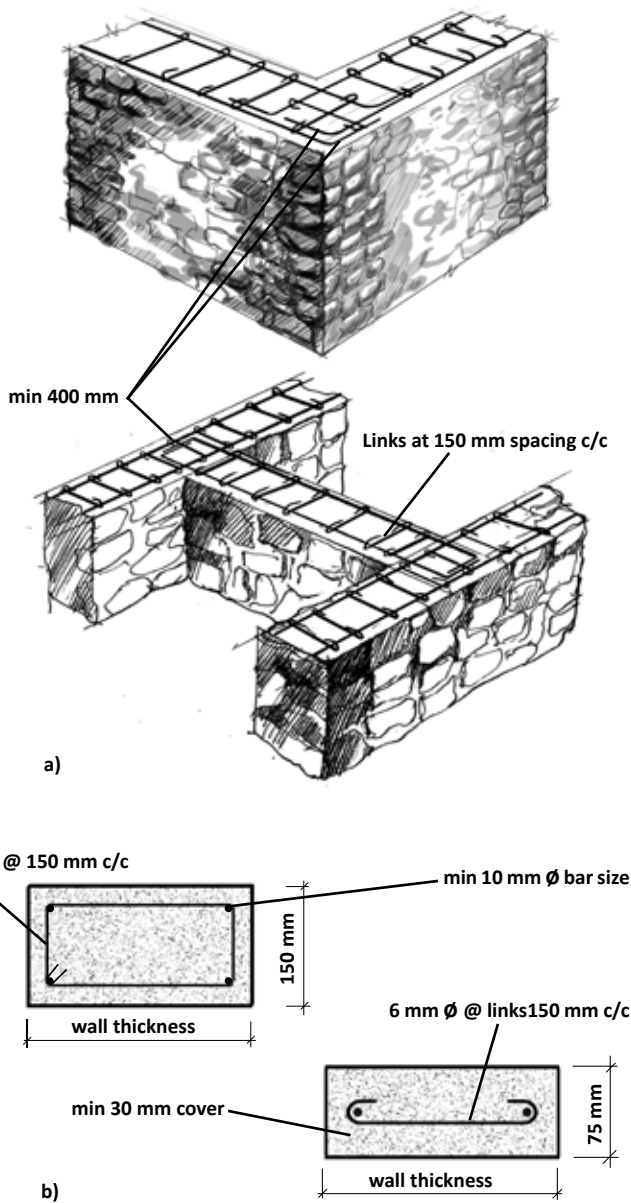

Figure 3.15 Stone masonry houses with RC lintel bands built after the 1993 Maharashtra, India, earthquake (source: GOM 1998)

*RC bands are generally a better choice than timber bands due to their low maintenance, long service life, and improved integration with the stone.*

the building in the community, the expected intensity of earthquake shaking (seismic zone), and the number of stories. Usually, two or four longitudinal bars of 10 to 16 mm diameter suffice. These bars must be tied with links or ties at a maximum spacing of 150 mm, as shown in Figure 3.16a (links are used for bands with two longitudinal bars and ties are used for bands with four bars). The required band depth depends on the number of bars: a 75 mm depth is sufficient when two bars are used, while a depth of 150 mm is needed when four bars are used, as shown in Figure 3.16b. The band width should match the wall thickness.

Proper bending of steel links and ties is critical for effectiveness of RC bands in an earthquake. Examples of poor construction practices are shown in Figure 3.17. When ties are used, it is very important to bend



Figures 3.16 RC seismic bands: a) reinforcement layout, and b) cross-section of RC bands with 2 and 4 bars (adapted from: GOM 1998)

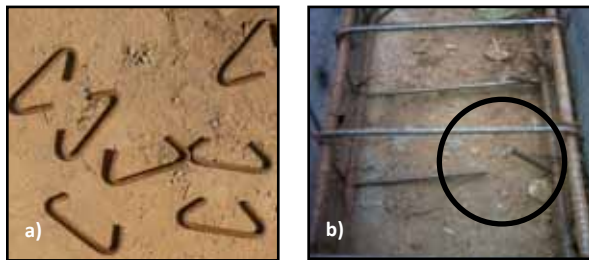

Figure 3.17 Inadequate bending of reinforcement in RC bands: a) links, and b) ties (photos: Smart Shelter Foundation)

them such that a closed loop effect has been achieved. Figure 3.17b shows an incomplete tie. It is also important that the ends of the ties are bent at 135 degree angles. Good reinforcement practice related to RC band construction is shown in Figure 3.18.

It is very important to provide sufficient cover to the reinforcement in RC bands. Inadequate cover results in corrosion of the reinforcement accompanied by cracking of the concrete. An example of exposed and corroded reinforcing bar in an RC lintel band is shown in Figure 3.19a.

A proper concrete cover can be achieved by casting concrete spacers, as shown in Figure 3.19b. The spacers can be made by cutting PVC pipes into 25 mm thick rings. These rings are filled with concrete and a steel wire is embedded in the center (wire is used to tie the spacers to the reinforcing bars). These spacers were successfully used by Smart Shelter Foundation in their school projects in Nepal. An example of an RC band under construction using spacers is shown in Figure 3.19c.

When reinforcing bars remain exposed after the removal of formwork, a 15 to 20 mm thick mortar overlay (1:3 cement:sand mix) should be provided at these locations.

Once the concrete is mixed and placed into formwork, it is essential to ensure proper compacting



Figure 3.18 Properly bent steel links for RC band construction (photo: Smart Shelter Foundation)



*In many countries, such as Turkey, Nepal, Pakistan, and India, timber bands have been used for centuries.*

using steel rods. If compacting is not done properly, segregation (honeycombing) of concrete may take place, as shown in Figure 3.20. This will result in concrete with poor compressive strength and corroded reinforcement. Note the excessively large aggregate size used for the concrete construction shown in Figure 3.20.



### Timber bands

In many countries, such as Turkey, Nepal, Pakistan, and India, timber bands have been used in stone masonry construction for centuries. At the present time, however, a scarcity of timber leads to unacceptably high costs and makes the use of timber in new construction impractical. Timber bands are made using a pair of parallel planks or runners nailed together with small cross members. The corners of the timber band should be strengthened by diagonal knee-braces that match the size of the cross members (Figure 3.21). The cross members should be placed either perpendicular to the long runners (like rungs on a ladder), as shown in Figure 3.21, or diagonally at approximately 45 degrees, to



**Figure 3.19** Concrete cover in RC bands: a) exposed bars due to inadequate cover, b) cement spacers made from PVC pipes, and c) RC band under construction showing use of cement spacers (photos: Smart Shelter Foundation)

**Figure 3.20** Poor concrete construction quality in an RC lintel band (photo: Smart Shelter Foundation)

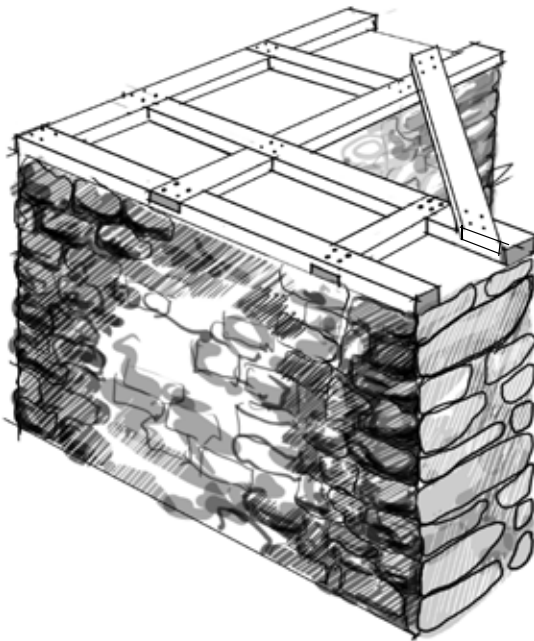

Figure 3.21 Timber band with a knee-brace at the corner

form a horizontal truss (Figure 3.22). The long timbers of the eaves-level timber band should be attached to the stone wall at regular intervals (this is required to tie the top band to the roof).

The detailing of a timber band is of critical importance. Wood spacers (the short timber pieces) should be properly nailed and the long runners should be properly spliced to achieve continuity (Figure 3.23).

The size and number of timber elements required depends on the distance between cross walls, the type of timber, the importance of the building, the seismic zone, and the building height. Usually, long parallel timber runners with dimensions of 50 mm by 100 mm and cross members with dimensions of 50 mm by 50 mm should suffice. Cross members should be placed about every 5 m along the runners.

Figure 3.23 Detailing of a timber band - joints and splices

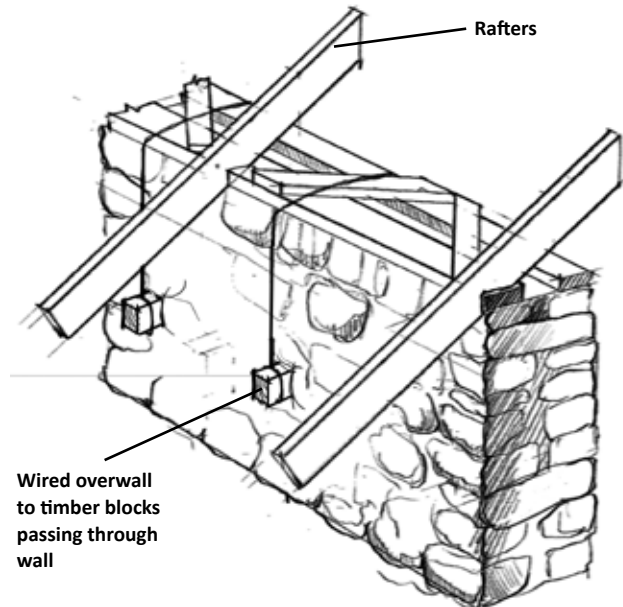
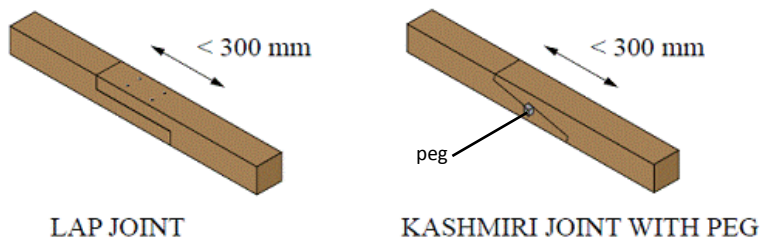

Figure 3.22 Timber band as a horizontal truss with cross members placed at a 45° angle to ensure roof anchorage

## Stone Masonry Walls

Proper wall construction is of critical importance for seismic safety. Important considerations that need to be followed are summarized below.

### Wall height

The story height in stone masonry buildings should be limited to 3.5 m when cement mortar is used for wall construction, and 2.7 m when mud mortar is used.

### Wall length

Construction of long unsupported walls is not recommended because it may result in a partial or total collapse due to out-of-plane seismic effects. The maximum distance between adjacent cross walls in a building should be less than 5 m when mud mortar is used and 7 m when cement mortar is used. Recommendations regarding the wall length are illustrated in Figure 3.24. When longer walls are required, it is possible to introduce buttresses at 5 m spacing; however, this requires more detailed planning

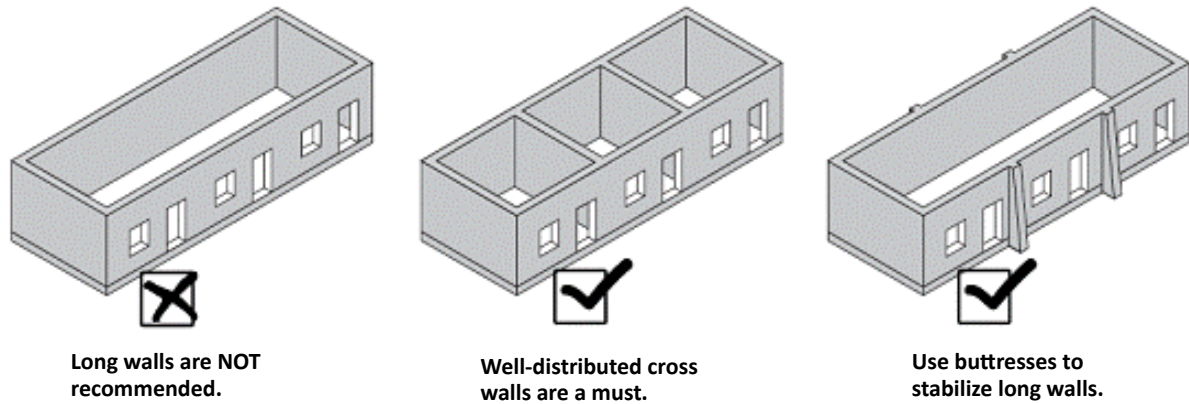

Figure 3.24 Recommendations related to the wall length (source: Bothara et al. 2002)

and a higher quality of construction. For more details about buttresses in masonry construction refer to IAEE (2004). The maximum lengths and heights of stone masonry walls are summarized in Figure 3.25.

When possible, construction of stone masonry gable walls should be avoided. The use of light-weight materials such as galvanized iron sheets or wood panels is recommended instead.

### Size and location of openings

Special consideration must be made regarding the size and locations of doors and windows within a wall, to ensure satisfactory building performance in

an earthquake. Recommendations related to opening size and locations are summarized in Figure 3.26.

When planning the openings in a stone masonry building:

- The number and size of openings should be minimized since excessive openings weaken the walls.
- Ideally, openings in opposite walls should be of similar size.
- Openings should be located away from the wall intersections, and placed as far apart as possible.

Figure 3.25 Recommendations regarding the length and story height of stone masonry walls

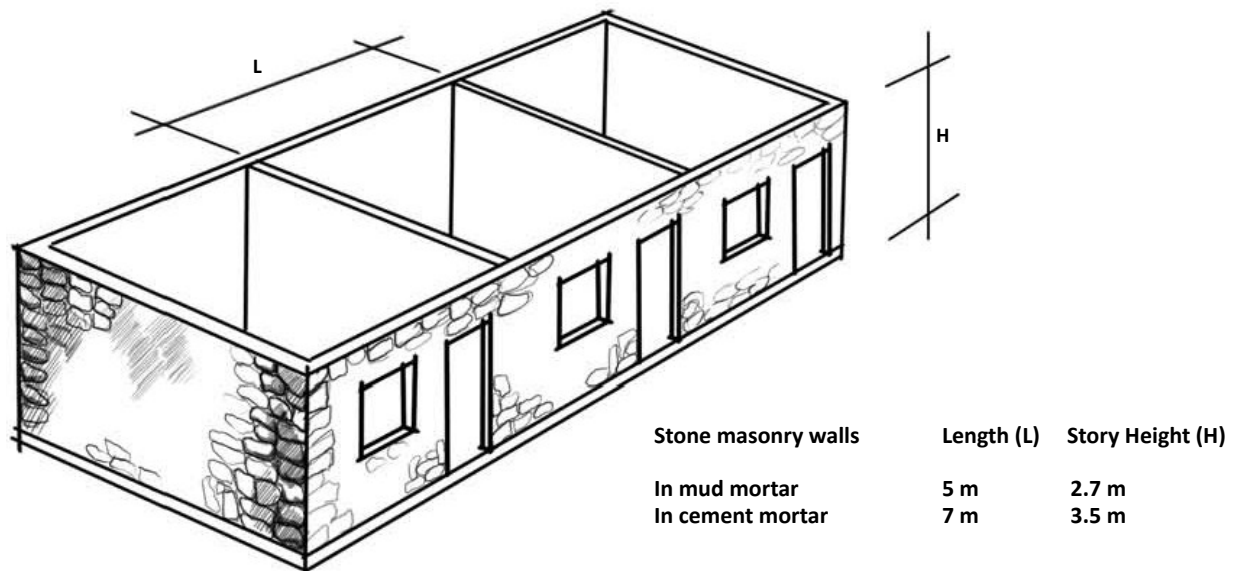

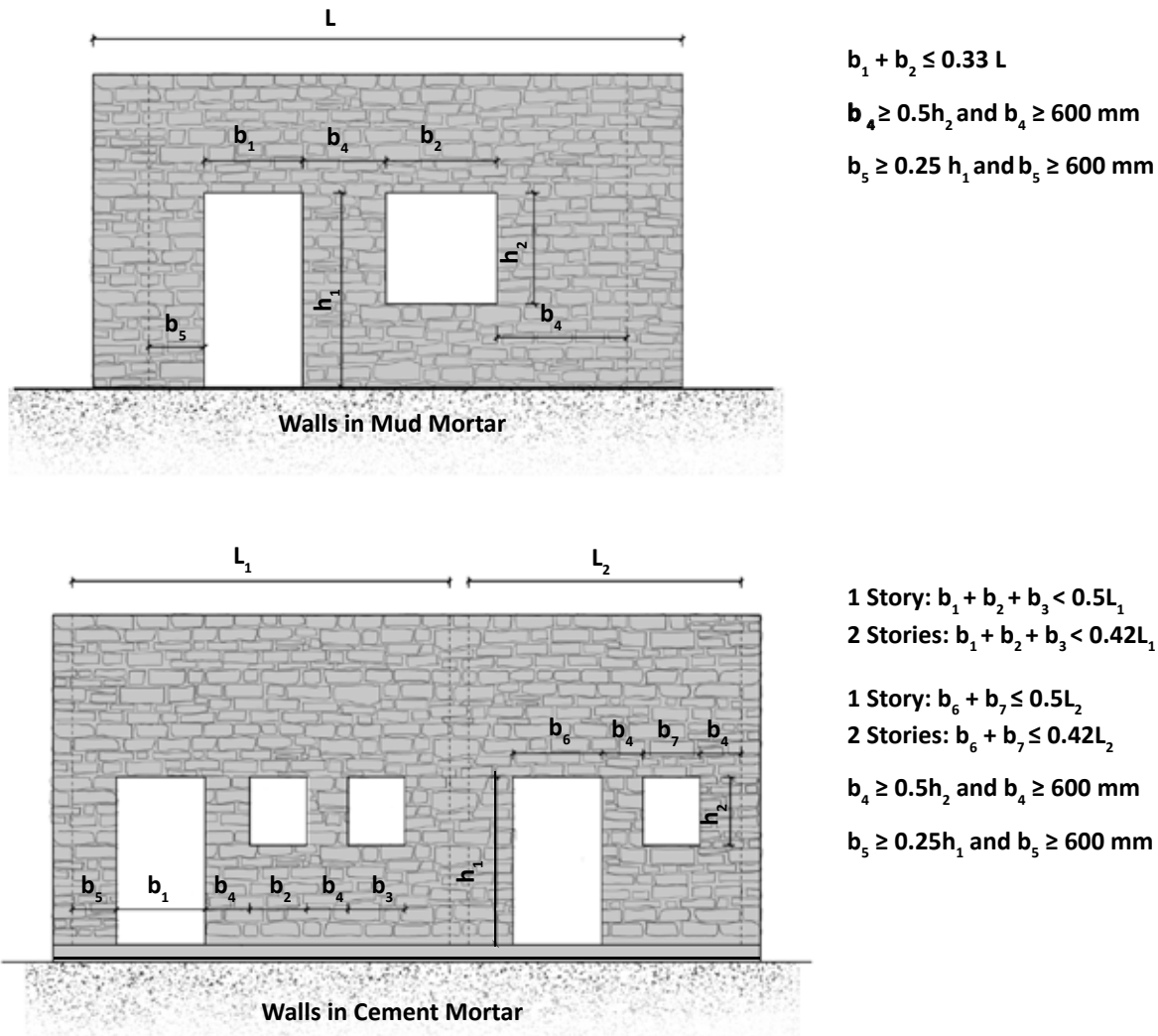

Figure 3.26 Recommended location and size of openings for stone masonry walls (source: IAEE 2004)

## Wall construction

Stone masonry walls are traditionally constructed using mud mortar. However, the use of cement or cement/lime mortar is becoming more common in modern construction. A detailed discussion on mortar properties is included later in this chapter.

## Wall thickness

The maximum thickness of a stone masonry wall should be 450 mm. Seismic forces are proportional to building mass (i.e., a wall of a larger thickness attracts higher seismic loads). Construction of thicker walls is uneconomical and also unsafe. However, ex-

cessively thin walls can be unstable, and these are difficult if not impossible to construct adequately. The recommended minimum wall thickness is 380 mm. An example of good stone masonry construction practice is shown in Figure 3.27.

## Bonding of wall wythes with through-stones

Through-stones (also known as bond stones) are long stones placed through the wall to tie wall wythes together and prevent delamination, which is one of the main causes of the collapse of stone masonry walls in earthquakes (see Chapter 2 for more details). The presence of through-stones in stone masonry walls



**Figure 3.27** Stone masonry in cement mortar with a wall thickness limited to 450 mm (note through-stones) (photos: S. Brzev)

is one of the most important earthquake-resistant provisions. Through-stones make the wall wythes perform like hands with interlaced fingers, as shown in Figure 3.28a. A wall with through-stones is shown in Figure 3.28b and one with two external wythes and an interior rubble core is shown in Figure 3.28c. The difference can be seen only when a vertical or horizontal wall section is exposed (the presence of through-stones in the wall cannot be easily confirmed by visual inspection).

Through-stones extending over the full wall thickness must be used every 600 mm in height and at a 1.2 m maximum spacing along the length (Figure 3.29). Constructing walls in lifts not exceeding 600 mm can facilitate the installation of through-stones.

When long stones are not available, a pair of overlapping stones can be used, each extending at least three-quarters of the wall thickness.

Contrary to the name, through-stones can also be made of concrete, wood, or steel bars with hooked ends embedded in concrete. Even though these elements are not made from stone, they serve the same purpose as through-stones, that is, they act as continuous members that tie wall wythes together. Provided that good quality concrete and steel reinforcements are used, cast-in-situ RC through-stones (bonding elements) are an ideal solution since they provide bonds between adjacent stones. It is important to provide reinforcement in RC bonding elements: for example, one 8 mm diameter steel bar is required for a bonding element.

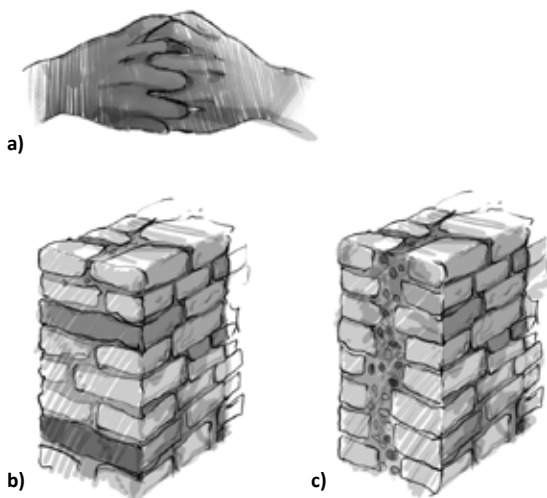

**Figure 3.28** Through-stones in stone masonry walls: a) through-stones act like interlaced fingers; b) a wall with through-stones, and c) a wall without through-stones (source: GOM 1998)

### Construction details at wall intersections

It is important to detail and construct wall intersec-

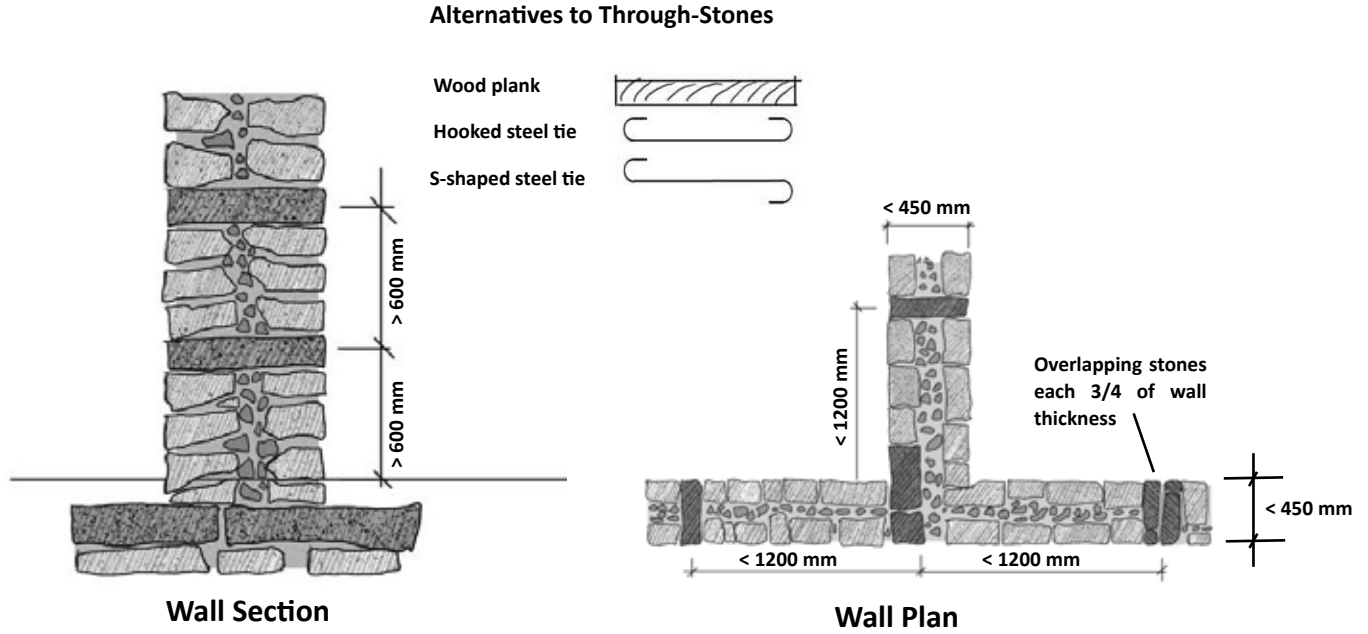

Figure 3.29 Proper placement of through-stones in stone masonry walls (adapted from: GSDMA 2001)

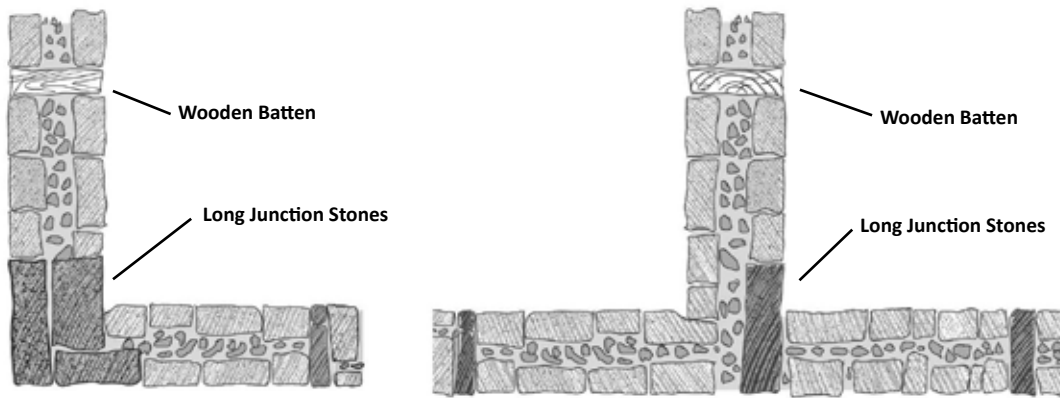

Figure 3.30 Placement of long stones at wall intersections (adapted from: Bothara et al. 2002)

tions carefully. All intersections should be strengthened with stitches to ensure the integral, box action of the building during earthquake shaking. These stitches could be constructed using long stones, RC bonding elements, steel mesh, or timber, depending on the availability of building materials and construction costs, as shown in Figures 3.30 to 3.33. Whenever possible, these stitches should be placed no further apart than 600 mm up the wall height.

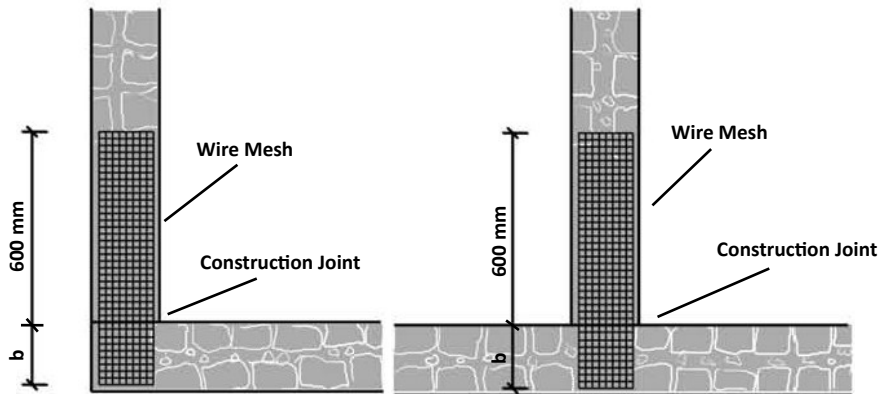

Figure 3.31 Construction of stitches made from wire mesh embedded in mortar at the wall intersection (adapted from: IAEE 2004)

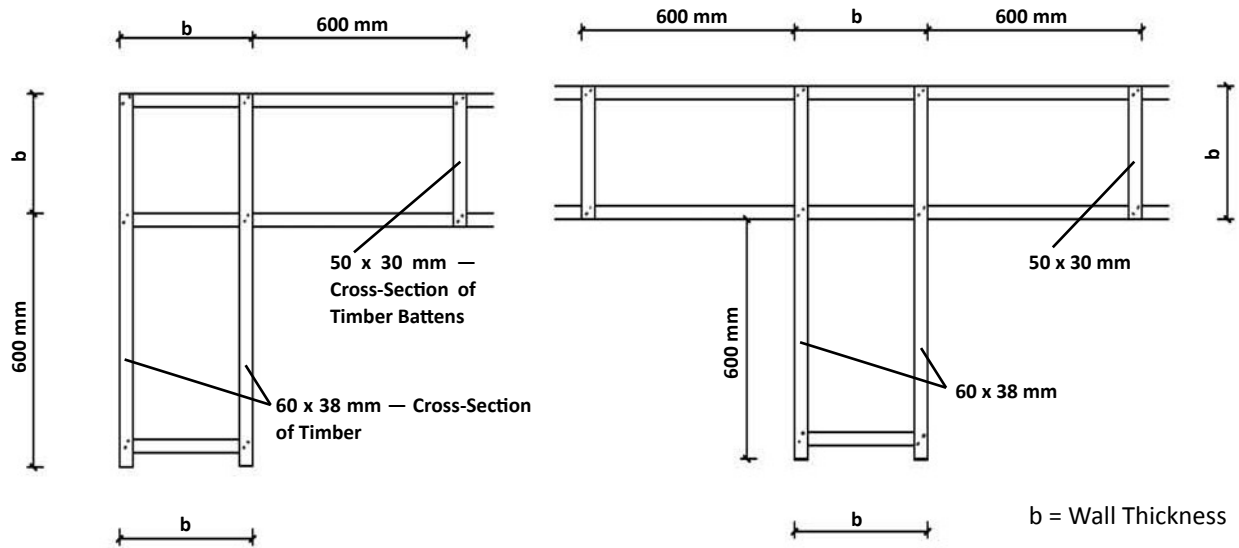

Figure 3.32 Stitches made from wood dowels at wall corners and intersections (adapted from: Bothara et al. 2002)

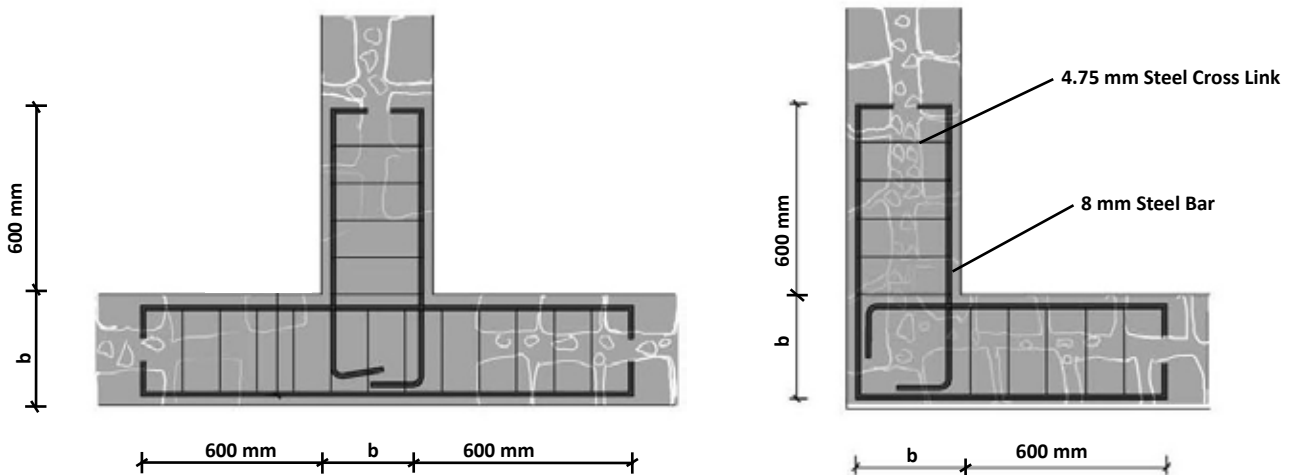

Figure 3.33 Wall stitches made from reinforced concrete with steel reinforcement (adapted from: Bothara et al. 2002)

## Floor and Roof Construction

Roof structures should be as light as possible. An example of a light roof is a timber or steel roof structure with metal roofing. Adequate connections between the roof rafters, floor joists, and the lintel or roof-level seismic band are critical for seismic safety, as shown in Figures 3.34 and 3.35.

The integrity of floor and roof structures and their connections to the supporting walls are of critical importance because they provide restraint, like a lid

on top of a box. Compared to masonry walls, timber and steel floors and roofs are flexible in their own planes, so they should be braced. Examples of diagonal bracing schemes are shown in Figure 3.36.

RC floor or roof slabs are heavy compared to timber and metal roofs, and that may be a disadvantage. However, these slabs are stiff in their own planes so they provide restraint. In most cases, wall-to-slab connections are adequate, but the top wall surface should remain rough to ensure a satisfactory bond between the walls and the slab built on top of the walls.

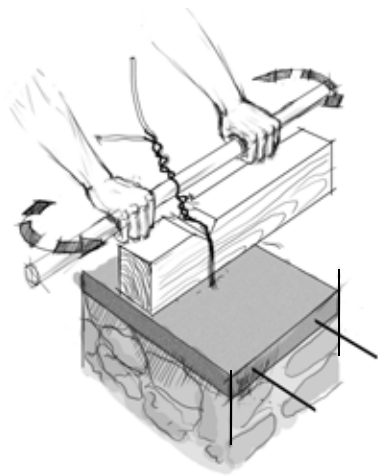

Use double 3 mm wire to anchor the beam and make a notch to stop movement in the beam.

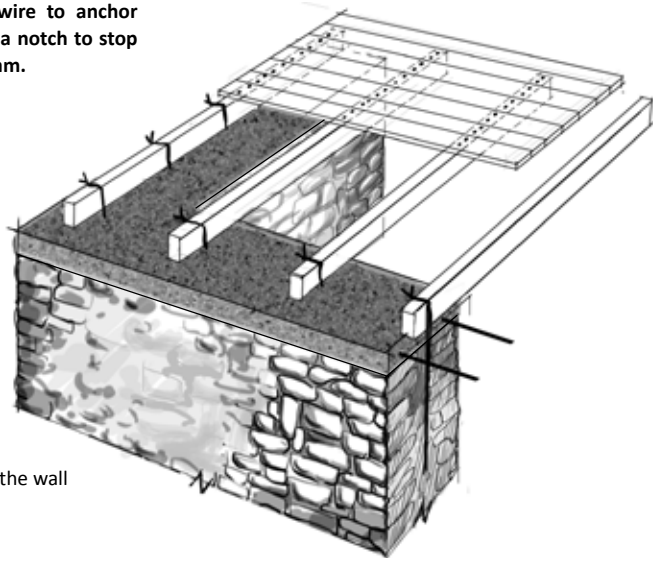

Figure 3.34 Tying floor joists to the wall

*It is important to ensure an adequate connection between the roof rafters and floor joists and the lintel- or roof-level seismic band.*

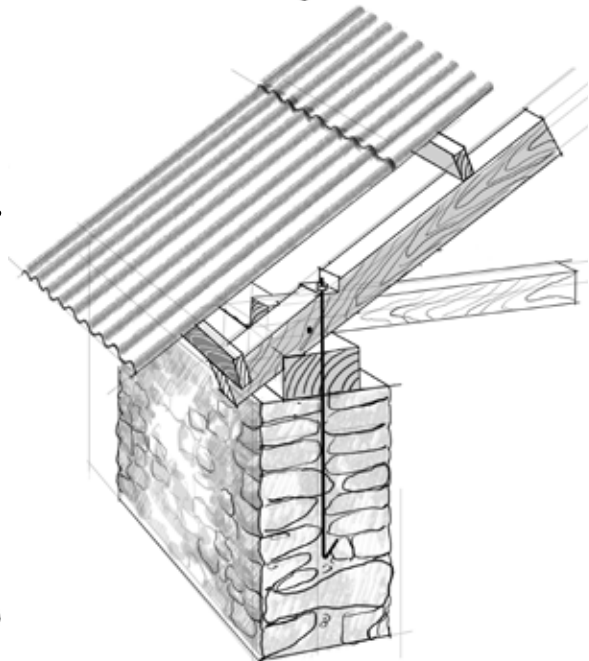
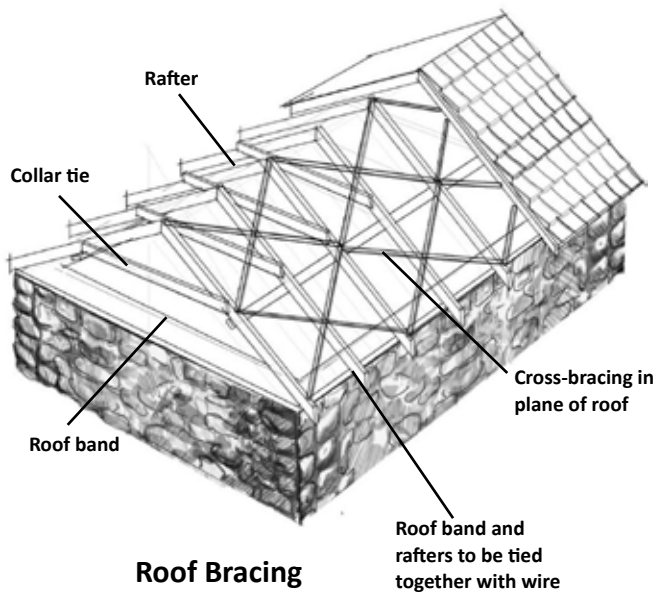
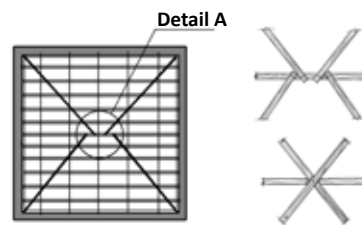

Figure 3.35 Tying roof rafters at the eaves level



**Roof Bracing**

Figure 3.36 Details of floor and roof bracing



**Floor Structure**

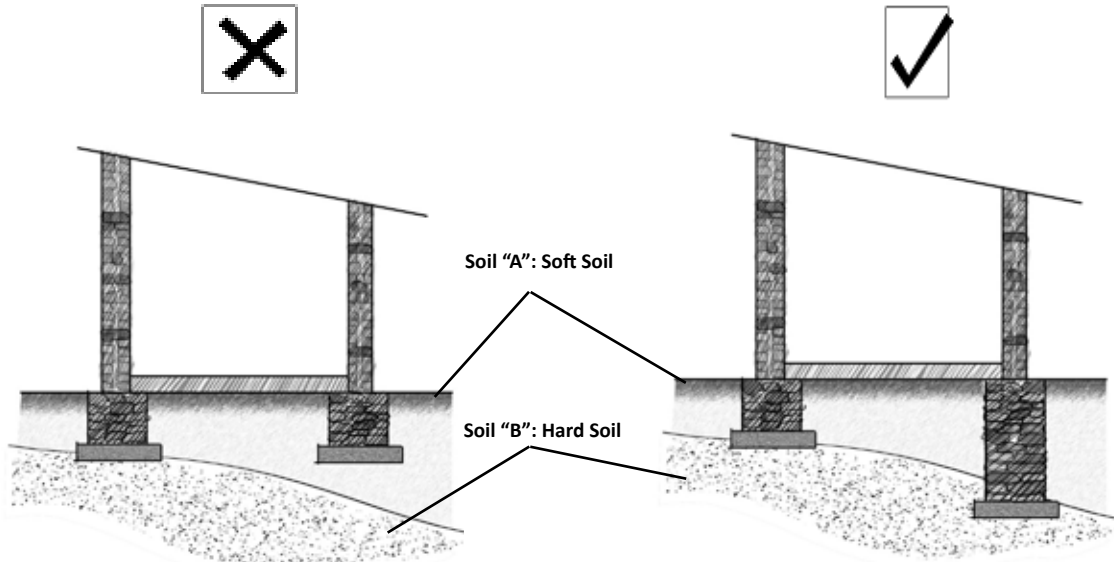

Figure 3.37 Different foundation depths are required for building sites with variable soil properties (source: GOM 1998)

## Foundations

Recommendations related to foundation construction are outlined below.

### Foundation depth

A 600 mm minimum depth is recommended for a foundation on hard stiff soil, and 1.8 m for a foundation built in a soft or clay soil area. As recommended earlier in this chapter, the building site should have a consistent soil type across the entire building area. If this is not possible, a foundation of variable width or depth may be required, as illustrated in Figure 3.37.

It is desirable to avoid the use of mud mortar in the construction of stone masonry foundations. If

mud mortar is used, it is advisable to provide an RC plinth band to avoid uneven building settlement and to tie building elements together at the plinth level (see Figure 3.38). If a timber plinth band is used, it should be installed 300 mm above ground. Figure 3.39 shows an RC plinth band under construction.

### Foundation width

Provide a 750 mm wide continuous strip footing constructed on hard soil for 450 mm thick stone masonry walls. When wall thickness is less than 450 mm, the footing width may be reduced, but should not be less than 600 mm. Note that a 750 mm foundation width may not be sufficient in soft soil areas. Local practices should be thought in deciding the type and width of the foundation.

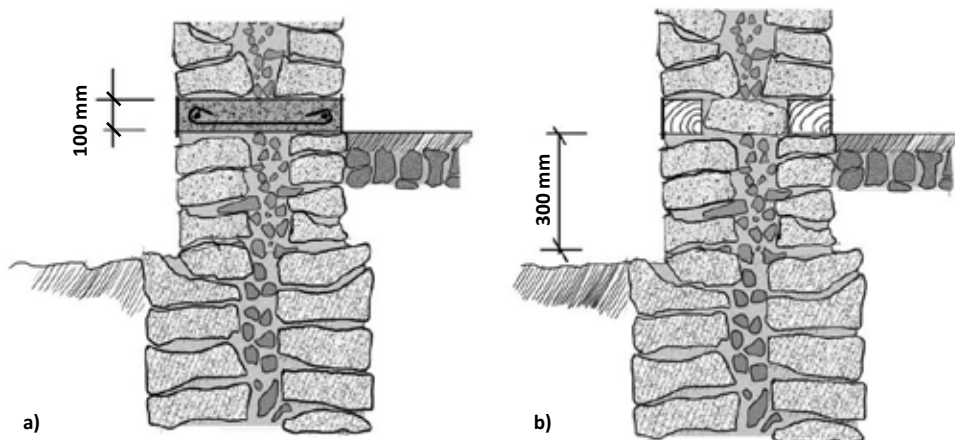

Figure 3.38 Stone masonry foundation with plinth bands: a) RC band, and b) timber band

## Construction Materials

Stone masonry must be constructed using good quality materials and following sound construction practices. General recommendations are outlined below.

### Stone

Good building stone should be hard, tough, compact grained, uniform in texture and color, and crack-free. A simple test to prove that stone is hard is to try to scratch it with a knife—hard stone cannot be scratched easily.

Round-shaped stone boulders commonly found in river valleys should not be used without further shaping (dressing). Figure 3.40 illustrates the collection of stones in a hilly area of Nepal.



**Figure 3.39** Construction of an RC plinth band using large stone rubble (also known as "stone-crete") (photo: S. Brzev)

### Sand

Sand used for mortar mix should be clean and free of organic matter. It should not contain more than 10% clay or silt (note that excess clay or silt can be removed from the sand by washing). The suitability of sand can be tested, as shown in Figure 3.41.



**Figure 3.40** Stone construction in hilly areas of Nepal: a) collection of stones, and b) delivery to the building site (photos: Smart Shelter Foundation)

*Good building stone should be hard, tough, compact grained, uniform in texture and color, and crack-free.*

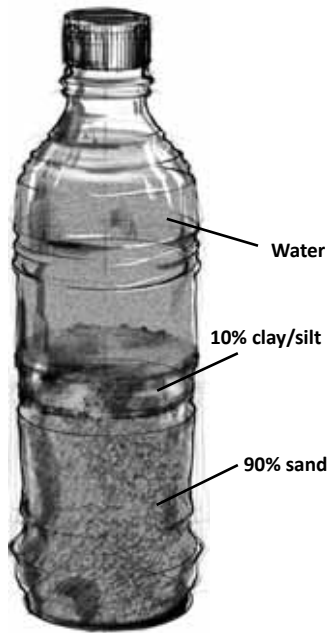

Figure 3.41 Testing of sand

The sand test is performed as follows:

Take a bottle and fill it with the sand until it is half full. Pour in clean water until the bottle is three-quarters full. Shake it violently for about half a minute and leave to settle for about one hour. Clean sand will settle immediately, while silt and clay will settle slowly on top of the sand. The thickness of the clay and silt layer should not exceed one-tenth of the sand below.



Different types of sand and their uses are illustrated in Figure 3.42. If the sand is too coarse, small pebbles must be sieved out. These pebbles could be added to aggregate for concrete construction. Sand from the sea or ocean should not be used due to the presence of salt, which causes corrosion of steel reinforcement.

### Cement

Cement is a key ingredient of both concrete and mortar. It must be of good quality and “fresh”. If the cement has large lumps, it indicates that it is stale and should not be used (see Figure 3.43).

### Mortar

Mud mortar has been used in stone masonry construction for centuries in spite of its low strength and poor durability. The properties of mud mortar, including its strength, can be improved by stabilizing it with cement, lime, etc. The use of cement or cement:lime mortar has been recommended by various codes and guidelines. A recent research study by Ali et al. (2010) has shown that use of cement mortar does not necessarily lead to improved seismic resistance of stone masonry buildings unless earthquake-resistant provisions are also incorporated.



Figure 3.42 Sand for different uses: a) fine sand for plaster construction; b) coarse sand for mortar and concrete construction, and c) excessively coarse sand (photos: Smart Shelter Foundation)

The authors of this document recommend the use of stabilized mud mortar at the minimum. The use of cement mortar or cement/lime mortar is also recommended, as its strength and durability are superior compared to mud mortar. The use of mud mortar is also acceptable provided that stones are shaped/dressed, the wall thickness is not excessively large, and through-stones are provided as per the recommendations presented earlier in this chapter.

Properties of different types of mortar are briefly discussed below.

### Cement mortar

Cement mortar used for wall construction should preferably be 1:6 cement:sand or 1:2:9 cement:lime:sand. The use of any lower strength cement-based mortar than those should be avoided.

### Mud mortar

Mud mortar must be of good quality and free of organic matter, pebbles, and other large particles which affect the mortar thickness. The sand content of the mud should be less than 30% in order to achieve sufficient cohesiveness. Soil should be thoroughly kneaded with water to achieve a dense mortar paste. The addition of lime helps increase the strength of mud mortar.

### Stabilized mud mortar

The strength of mud mortar can be increased by modifying its soil properties to stabilize it. Different additives such as ash, lime, cement, or fibers can be used for this purpose. To achieve good results, it is important that the additives are mixed well with the soil.



**Figure 3.43** Cement with large lumps should not be used for construction (photo: Smart Shelter Foundation)

Ash, produced by burning coal, coke, or rice husks, can be used to stabilize mud mortar (usually 5%–10% by volume). Ash can be somewhat pozzolanic and additional improvements are possible when combined with lime. Lime can also be added for stabilization, (3%–10% by volume, the higher, the better). Lime should be added to a soil at least 2 hours (preferably 8 to 16 hours), before use to allow short-term stabilization to take place, thus making the soil easier to work and compact. It is appropriate to mix lime with soils characterized by a relatively high proportion of clay. Mud can also be stabilized by adding cement, which improves both the dry and wet compressive strength. Some soils require only a 3% cement by volume, but usually 5% to 8% is recommended. A variety of fibrous additives including straw, chaff or husks, hay, hemp, millet, sisal, or elephant grass can be used. Cow, horse, or camel dung can also be used for stabilization.

### Lime mortar

Lime mortar is a mix of lime putty and an aggregate (usually sand). Lime mortar has a lower compressive strength than cement mortar, but its strength is adequate for stone masonry construction. Lime mortar is more workable than cement mortar, and it is more resilient to cracking than cement mortar, which is more brittle. When lime mortar is subjected to tension numerous micro-cracks develop and subsequently recrystallize when exposed to air. Lime mortar thus has an ability to self-heal, which is not true of other mortar types.

A typical lime mortar mix ratio is 1:3 lime putty to sand. The sand must be washed, well graded, and sharp. Other materials could be used instead of sand, such as pozzolan, powdered brick, heat-treated clay, silica fume, fly ash, or volcanic materials.

Care should be taken to avoid shrinkage and cracking in lime mortar. This can happen due to the use of poor-quality lime putty and sand, excessively fine sand, high water content in the mortar mix, or excessive mortar thickness.

## Concrete

It is very important to ensure the use of good quality concrete for RC band construction. Typically, a concrete with a 1:2:4 cement:sand:aggregate ratio can be used. Sand properties were discussed earlier in this chapter. Aggregate for concrete construction can be obtained by crushing the stone, as shown in Figure 3.44. The aggregate size must not exceed 20 mm.

A measuring box such as that shown in Figure 3.45 a can be used to ensure the consistent proportion of materials in concrete mix. The box dimensions are 300 mm x 300 mm x 350 mm (or 1 ft x 1 ft x 1 ft 2 in). In many countries, cement is available in 50 kg bags, and measuring boxes should have the same volume as one bag of cement. Therefore, two boxes filled with coarse sand and four boxes of aggregate would be required for a 1:2:4 concrete mix.



**Figure 3.44** Stones can be cut to produce aggregates for concrete construction—an example from Nepal (photo: Smart Shelter Foundation)

## Reinforcement

When choosing and using reinforcing steel, consider the following:

- Deformed bars should be used for longitudinal steel, while plain bars can be used for stirrups and ties.
- Re-bent bars should not be used in construction. Over-bent or over-stretched lengths form weak spots in the reinforcement.
- The bend diameter of bars should not be less than six times the bar diameter. Steel reinforcement should not snap at this radius.



**Figure 3.45** Measuring concrete materials: a) proportioning concrete ingredients using a measuring box, and b) a measuring box (photos: Smart Shelter Foundation)

- Reinforcement manufactured from scrap steel must be avoided. Such steel is of widely variable quality and it is inappropriate for use in RC construction.

- Reinforcing steel should be clean and free of loose mill-scale, dust, rust, paint, oil, grease, or other coatings which may impair or reduce bond. Loose particles should be removed from the steel surface using wire brushes. Bar cross-sectional area should not be reduced due to corrosion by more than 5%.

## Do's and Don'ts

This section provides a list of do's and don'ts that must be followed when selecting and using construction materials.

### MORTAR DO'S:

Use mortar in stone masonry as economically as possible.

Use clean sand for mortar and concrete construction.

Use fresh and lump-free cement for mortar and concrete.

Mix the dry ingredients (sand and cement) together before adding water.

Protect the mortar or concrete-mixing area from wind, rain, and sunshine.

### MORTAR DON'TS

Don't use or re-use mortar that has already hardened. As cement mortar sets relatively quickly (in approximately 30 minutes), it should never be mixed in huge quantities.

Don't use sea sand or sand containing a large amount of silt or clay.

Don't use cement that has already set.

### CONCRETE DO'S

Calculate how much finished concrete is required and estimate the amount of cement, sand, coarse aggregate, and water required for construction.

Use clean sand and aggregates.

Use measuring boxes.

Mix the dry ingredients (sand, cement, and aggregates) together before adding water.

Double check the formwork to ensure its stability, dimensions, water-tightness, and placement of reinforcements before placing concrete.

Concrete, stone masonry, brick masonry, plasterwork, cement flooring work, etc. should be cured for seven days.

### CONCRETE DON'TS

Don't place concrete more than one hour after adding water to the mix.

### MASONRY DO'S

Use shaped/dressed stones.

Use through-stones to stitch wythes together.

### MASONRY DON'TS

Don't build a stone masonry wall higher than 1 m per day.

Don't lift stones up for final adjustments after placing them into the mortar bed.

Don't level/top-up the stone masonry wall with mortar at the end of the day.

Don't allow anyone to stand on top of the newly built stone wall.

### STEEL REINFORCEMENT DO'S

Bending diameter of reinforcement should be more than six times the bar diameter.

### STEEL REINFORCEMENT DON'TS

Don't store the steel bars directly on the ground. Avoid using bars which show signs of corrosion or are covered by dirt.

Don't use straightened and re-bent reinforcement in reinforced concrete construction.



## 4. Retrofitting a Stone Masonry Building

### Seismic Retrofitting: Key Strategies and Challenges

Past earthquakes have shown that damage to and the collapse of stone masonry buildings cause major human and economic losses in areas where this construction type is widespread. The causes of poor seismic performance of these buildings are explained in Chapter 2. However, massive demolition and replacement of these vulnerable buildings is neither affordable nor feasible due to historical, cultural, social, and economic constraints. Existing stone masonry buildings located in areas of high seismic risk can be economically retrofitted, unless their condition is very dilapidated. This chapter presents cost-effective strategies for retrofitting stone masonry buildings in order to enhance their seismic performance.

Many stone buildings have been constructed using weak mortar and local construction materials; this indicates that their initial construction cost was very low. Most of these buildings were built in a very informal manner by the owners themselves, avoiding any major cash outlay. These buildings need a significant and costly intervention to bring them up to the safety levels required by current seismic codes. Protection of the lives of building occupants in an earthquake is the main goal of the retrofit (this is referred to as “life safety” performance in building codes). In many cases the life safety level prescribed by building codes cannot be achieved without major structural intervention and investment. Retrofitting is considered to be unfeasible when the required capital investment exceeds the initial building cost. Costs associated with demolition, rubble disposal, and reconstruction determine the feasibility of the retrofit project.

Legal issues arise when the safety of a building is dependent on adjacent housing units, as in the case of row buildings (townhouses) where several owners

share a building, and housing units have a common wall. Retrofitting a single home has little benefit in row housing if adjacent housing units are seismically deficient.

The appropriate retrofit strategy for a specific project depends on a number of technical issues related to the existing building, including the structural system, construction materials, quality of construction, building condition, site conditions and constraints, intensity of damage sustained by the building in past earthquakes (if any), and the expected ground shaking in the area. It is not possible to prescribe retrofitting solutions without understanding the socio-economic context of a particular building.

The following critical strategies have the highest cost-to-benefit ratio in terms of improving the seismic resistance of stone masonry buildings:

- Enhancing integrity of the entire building by ensuring a box-like seismic response,
- Enhancing the wall strength for in-plane and out-of-plane effects of seismic loads, and
- Improving floor and roof diaphragm action.

An additional strategy is to strengthen the existing foundation, but this is not considered practical and economically feasible in most cases.

This chapter provides an overview of established seismic retrofitting strategies for stone masonry buildings that have been used in post-earthquake rehabilitation efforts around the world; some examples include the 1979 Montenegro earthquake, 1993 Maharashtra and 2001 Bhuj (India) earthquakes, the 2002 Molise (Italy) earthquake, and the 2005 Kashmir (Pakistan) earthquake. For a more detailed discussion on various retrofitting strategies, the reader is referred to several publications including EERI (2006), UNCRD (2003),

*Existing stone masonry buildings located in areas of high seismic risk can be economically retrofitted, unless their condition is very dilapidated.*

GSDMA (2002), Tomazevic (1999), GOM (1998), Momin et al. (1996), BMTPC (1994), and UNIDO (1983).

## Enhancing Building Integrity

### Why is building integrity critical?

Building integrity is the most important prerequisite for survival during earthquake shaking (this was discussed in detail in Chapter 3). The integrity of an existing building can be enhanced by means of the following provisions:

- Tying walls together by means of external steel tie-

rods, reinforced concrete bands, or bandages,

- Connecting the walls at corners or intersections,
- Improving floor and roof integrity, and
- Strengthening wall-to-floor and wall-to-roof connections.

Figure 4.1 presents models used for shake-table testing performed after the 1993 Maharashtra, India, earthquake, with an objective to compare the seismic performance of strengthened and unstrengthened uncoursed stone masonry buildings. Two one-half scale models of a traditional building with uncoursed random rubble stone masonry walls and timber roofs were tested on a wagon-type



**Figure 4.1** Effectiveness of seismic retrofitting methodology for stone masonry buildings: a) strengthened model, b) unstrengthened model after testing, and c) models at the end of the experiment (unstrengthened model shown on the left) (source: GOM 1998)

field shake-table that simulated earthquake effects. The strengthened specimen survived all 12 tests, while the unstrengthened one collapsed. This testing confirmed the effectiveness of seismic strengthening provisions, including bandages and through-stones, in resisting earthquake effects.

*The strengthened specimen survived all 12 tests, while the unstrengthened one collapsed.*

## Ties

Iron ties have been used for many centuries to strengthen masonry buildings in Mediterranean Europe, including Italy and neighboring countries. Steel ties have been used for seismic retrofitting in several post-earthquake projects in Europe (including after the 1979 Montenegro earthquake); for more details refer to UNIDO (1983) and Tomazevic (1999). Steel ties are 16 to 20 mm threaded rods installed horizontally beneath the floors and roof. These rods are restrained at the ends by steel anchor plates. Steel tie concepts and layouts are shown in Figures 4.2 and 4.3. The rods help to connect the walls at floor and roof levels and thus prevent separation during ground shaking. In the case of flexible roofs and floors, ties are effective in increasing the stiffness of these diaphragms. Experimental studies on brick masonry building models tested on a shake-table with and without ties confirmed the effectiveness of ties in preventing the separation and disintegration of walls (Tomazevic 1999). An example of a field application is shown in Figure 4.4.

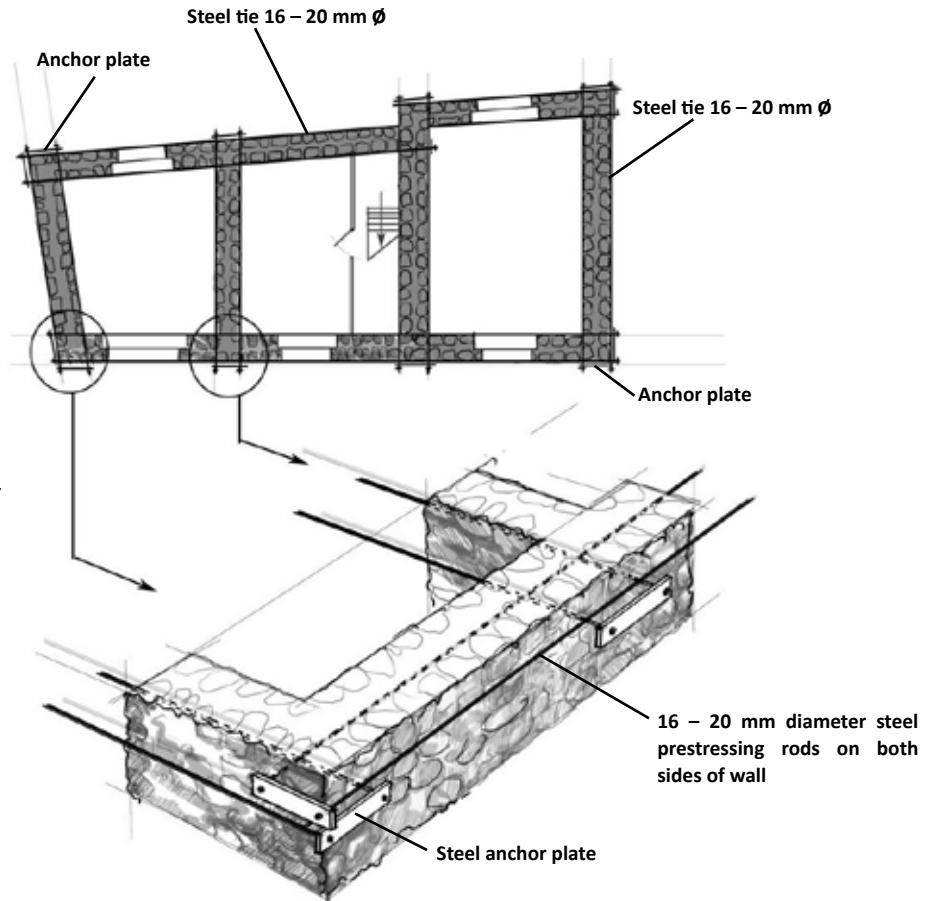

Figure 4.2 Plan view of a building showing layout of steel ties and anchor plates (adapted from: Tomazevic 1999)

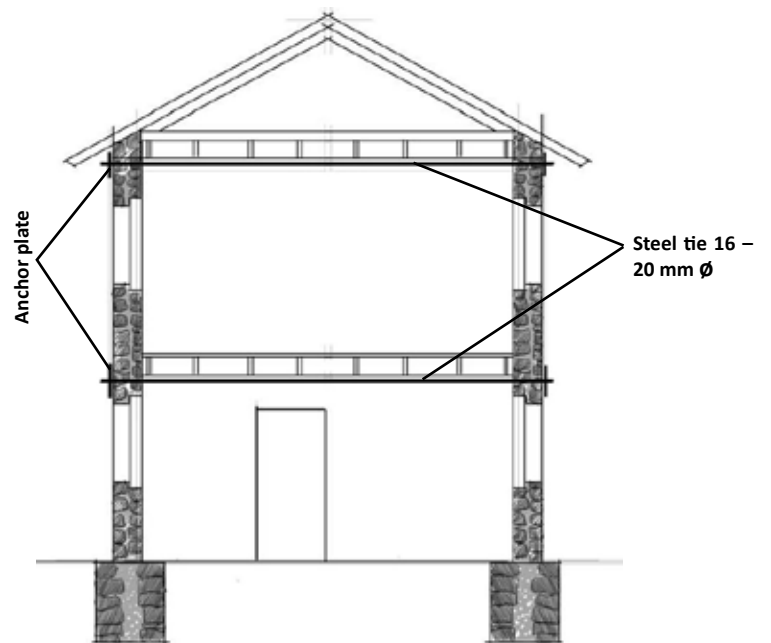

Figure 4.3 A vertical building elevation showing ties beneath the floor level (adapted from: Tomazevic 1999)



**Figure 4.4** A field application of ties in Slovenia: a) and b) installation of steel ties after the 1998 Bovec, Slovenia, earthquake (note that anchorage end-plates are yet to be attached), and c) an example of a retrofitted building (photos: M. Lutman)

## Bands and Bandages

### Bands

Reinforced concrete (RC) bands or bandages can be used as an alternative to ties to enhance the overall building integrity. Both bands and bandages act like rings or belts at the level where they are applied, as discussed in Chapter 3. The installation of an RC band in an existing building requires a portion of the wall above the band to be removed and rebuilt, or chases need to be cut in the walls. On the other hand, a bandage can be installed without demolishing a portion of the wall, since it is an external application. The provision of bands is thus more invasive compared to bandages and could cause damage in the wall if not installed carefully. On the other hand, the successful application of a bandage requires attention to surface cleaning and the provision of cross-wall anchors, which may be challenging in the case of thick stone masonry walls or when artisan skills are at a low level. RC bands and bandages are most effective when constructed at the lintel or roof levels (above doors and windows).

Figure 4.5 illustrates the steps in installing an RC band at roof level in a building with a timber frame and a flexible timber roof. In this case, the roof is not connected to the walls; this is typical for rural construction

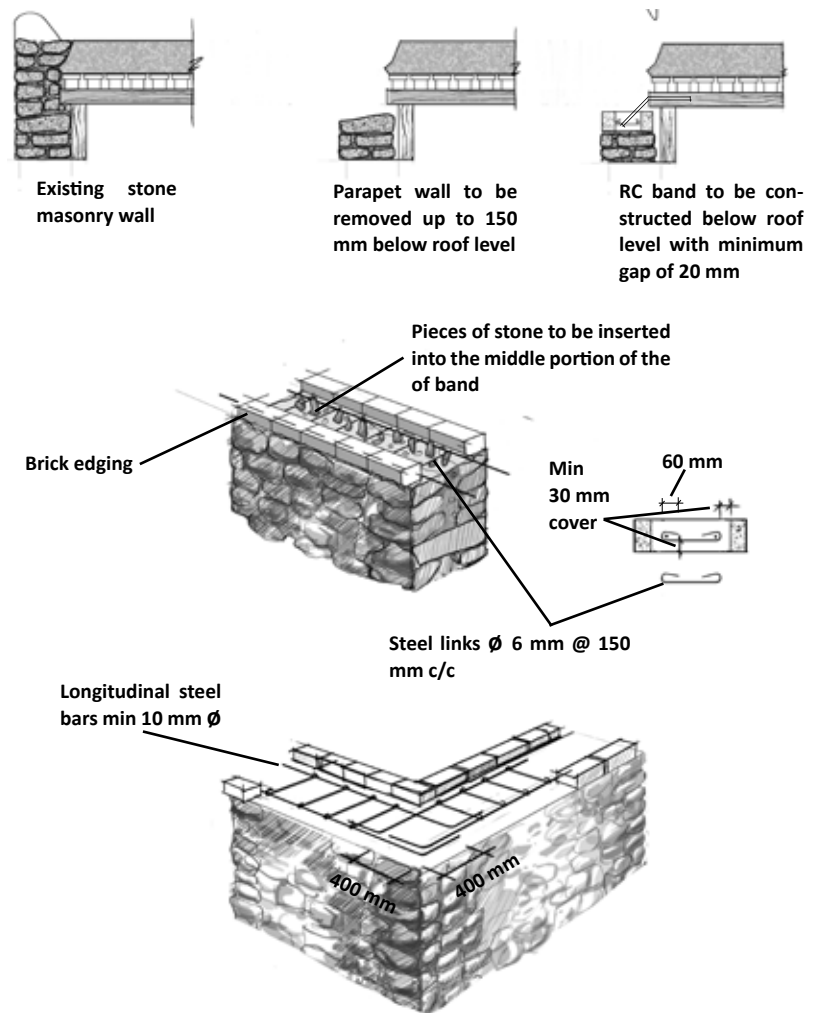

**Figure 4.5** Installation of an RC band at the roof level in a stone masonry building (source: GOM 1998)

in Maharashtra, India. The required size and number of reinforcing bars in the bands will depend on the



**Figure 4.6** An example of a field application of an RC band in an existing stone masonry building in Maharashtra, India: a) RC band installation completed (note brick edging at the band level and a newly constructed portion of the wall above the band), and b) RC band at the roof level underneath the timber beams (note that roof is supported by an interior timber frame) (photos: S. Brzev)

wall span between the adjacent cross walls and the seismic zone at the site. For a detailed explanation of RC band construction in stone masonry buildings refer to GOM (1998). A field application of RC band construction in Maharashtra, India is shown in Figure 4.6.

A common practice in stone masonry buildings is that the roof is supported by the walls (unlike the case of Maharashtra, India described above). When a new RC band is constructed beneath the roof, it must be anchored to the roof; this can be achieved by using anchor bolts, as shown in Figure 4.7.

### Bandages

Bandages are thin reinforced mortar overlays bonded to the walls at the lintel, floor and/or eaves levels (as an alternative to RC bands). When constructed properly, bandages can be effective in confining the masonry walls they are attached to (similar to a wide belt). Bandages should be provided on both the interior and exterior wall surfaces. The width of the bandage varies, but a typical width is on the order of 200 to 400 mm, and the mortar thickness ranges from 30 to 50

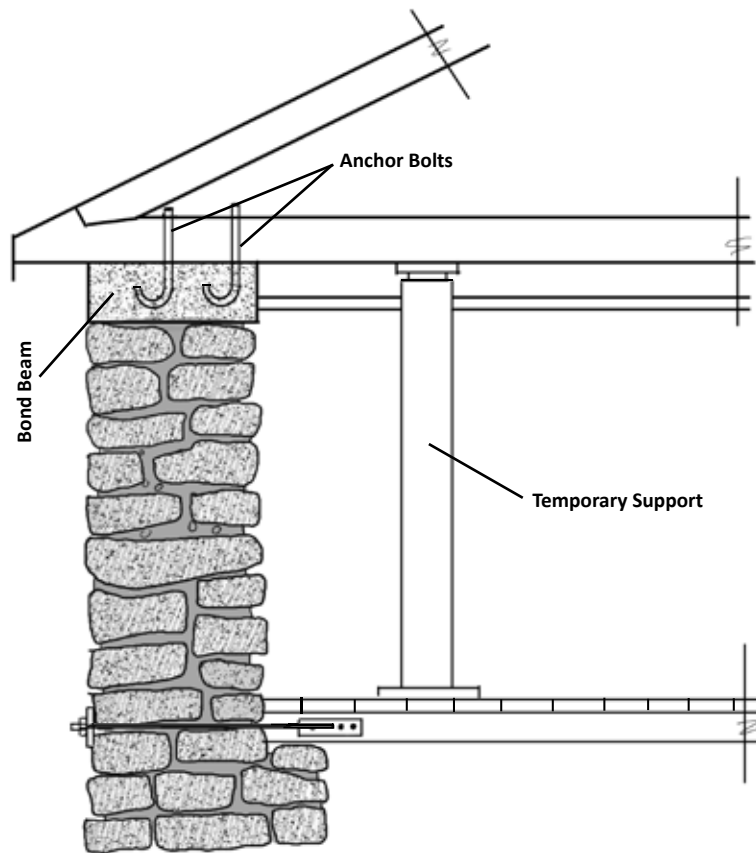

**Figure 4.7** A new RC band must be anchored to the roof (adapted from: Tomazevic 1999)

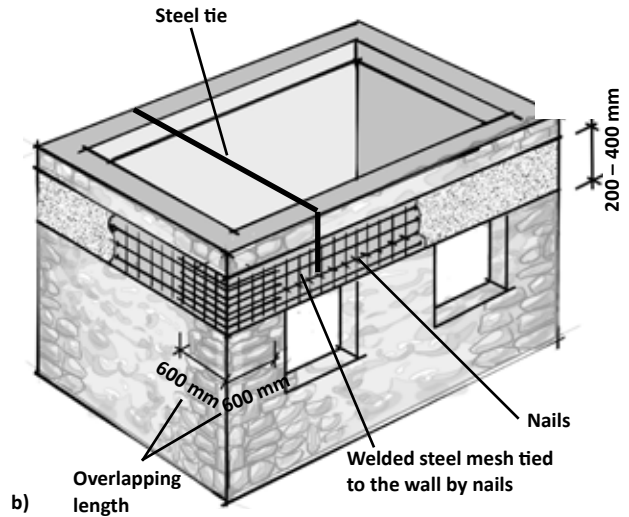

Figure 4.8 Construction of a reinforced concrete bandage: a) a retrofit application in Maharashtra, India and b) concept (source: GOM 1998)

mm (GOM, 1998). Reinforced cement and sand plaster or micro-concrete (with a maximum aggregate size of 5 mm) is applied in two layers, and the welded wire mesh reinforcement is placed between them. A connection between the exterior and the interior bandage is achieved by providing through-wall anchors (Figure 4.8).

Bandages should be continued around all re-entrant wall corners, as shown in Figure 4.9. A steel tie rod can be used to ensure continuity.

### Strengthening of Wall Intersections

A few different approaches can be used to strengthen wall intersections. In some existing stone masonry buildings, wall intersections are in good condition, and long stones are provided at the intersections. In such cases, strengthening the wall intersections is not required. However, when wall intersections are deficient due to poor construction or an absence of header stones, splints in the form of L-shaped mortar overlays can be used to strengthen these deficient areas. Splints are applied to the

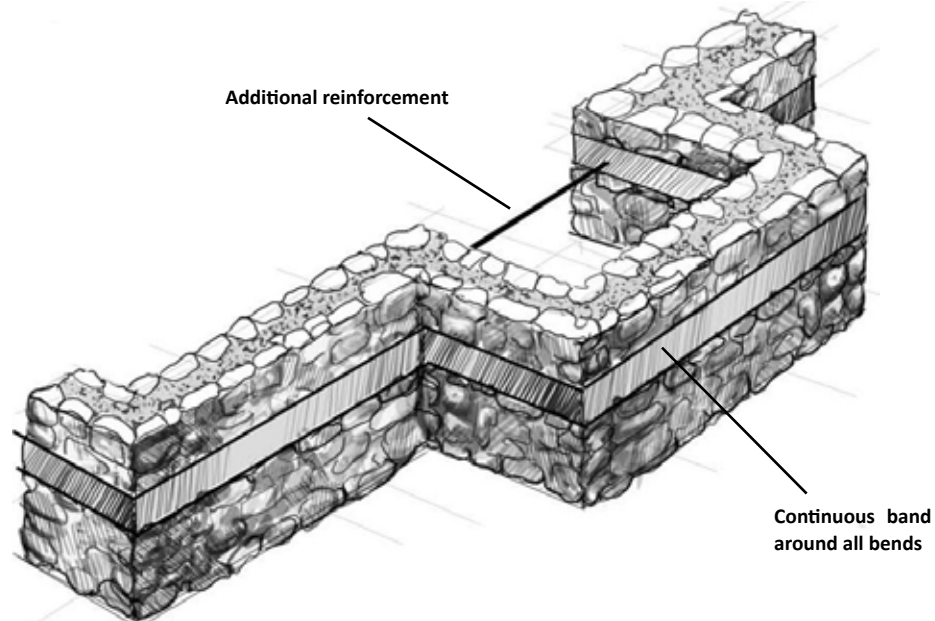
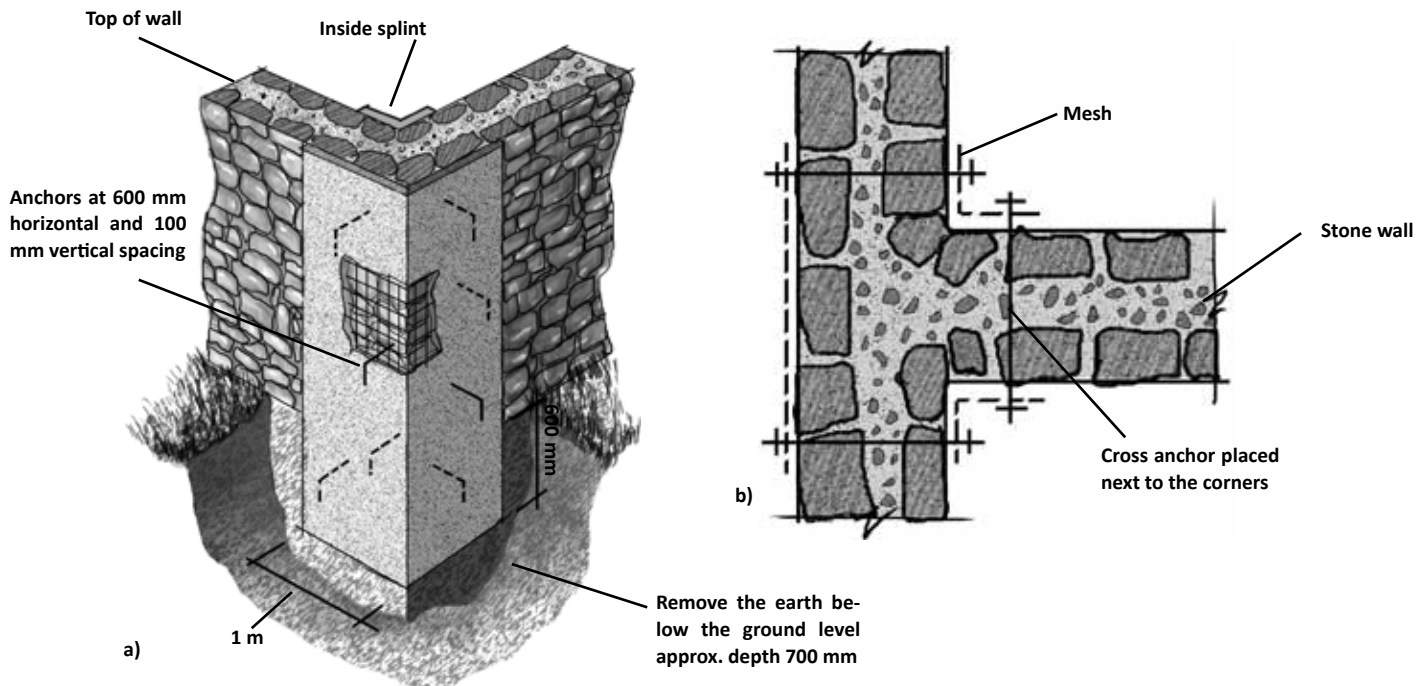

Figure 4.9 Continuing a bandage in re-entrant walls (source: R. Desai)

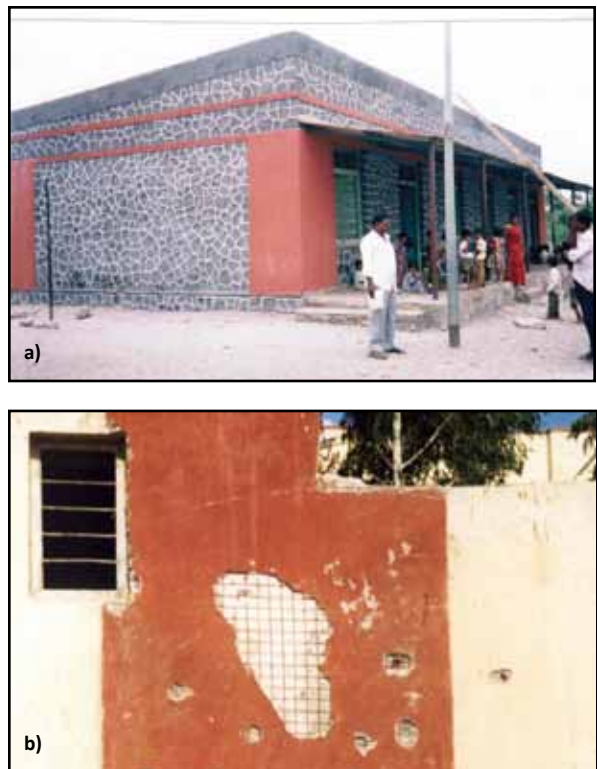

**Figure 4.10** Strengthening of intersecting walls using splints : a) a concept, and b) anchorage - anchor bars tying splints on both sides of wall (source: GOM 1998)

wall in two layers and are reinforced with welded wire mesh. Ideally, splints are applied to both the exterior and interior wall surfaces (Figure 4.10). The construction of splints and bandages is similar. It is very important that the wall surfaces are clean and that the splints are properly anchored to the walls. Anchorage can be achieved by dowel bars embedded in concrete-filled holes in the wall, as shown in Figure 4.10a. Through-wall anchors can be used when the wall thickness is not excessive, as shown in Figure 4.10b.

Two examples of field applications are shown in Figure 4.11. Figure 4.11a shows a school building retrofitted after the 1993 Maharashtra, India, earthquake using splints at the wall intersections and RC bands at the lintel and roof levels. Figure 4.11b shows an unsuccessful application, where the concrete overlay fell off and the reinforcement was exposed. It can be also observed that the wall surface was not properly prepared since the original plaster had not been removed prior to the splint application. This is an unacceptable practice and such a retrofit is useless.

Where technology is available and affordable, connections between intersecting walls can be enhanced by embedding a horizontal post-tensioned steel anchor into a 60 mm hole drilled through



**Figure 4.11** Strengthening of intersecting walls: a) retrofitted school building in India, and b) an unsuccessful retrofit application (photos: S. Brzev)

the wall (Figure 4.12). The rod is bonded to the wall by means of epoxy grout. The exterior steel plates and nuts are installed and covered by the grout to preserve the exterior appearance of the wall. This technique was used for retrofitting stone masonry walls in Italy after the 2002 Molise earthquake (Maffei et al. 2006). Although expensive, this technology could be applied in stone buildings of historic importance.

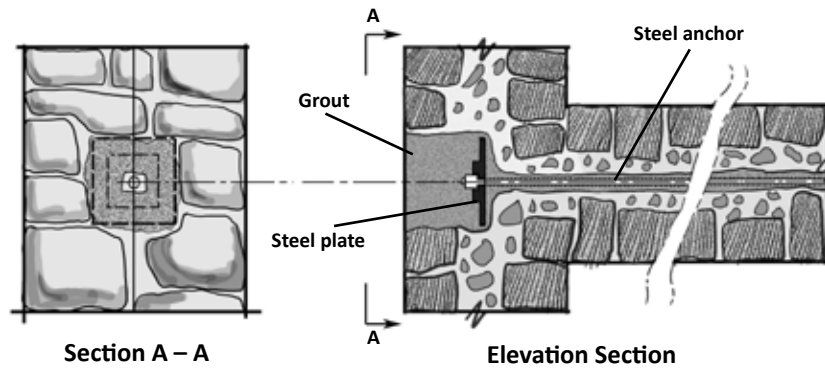

Figure 4.12 Installation of post-tensioned steel anchors to enhance connections between the intersecting walls (source: Maffei et al. 2006)

When the wall intersections are severely damaged, it is better to rebuild the damaged portions. This requires providing temporary support for the floor or roof structure above the wall. Special attention should be paid to achieving a strong bond between new and existing masonry.

### Enhancing Wall-to-Floor and Wall-to-Roof Connections

One of the most critical seismic retrofitting provisions for stone masonry buildings is to tie the exterior walls to the floors and roof. Many existing stone masonry buildings have flexible timber floors and roofs, many of which have deteriorated. As a minimum, the connection between floor and roof components can be improved by providing additional nails or bolts. In many cases, a retrofit of the existing floors and roof is required. This can be achieved by stiffening the floor or roof structure, and enhancing the connections between floor or roof and walls with one of the following techniques:

**1. Installing new steel straps:** New steel straps can be installed to connect the exterior walls to a timber floor, as shown in Figure 4.13a (UNIDO, 1983). This is convenient when the floor beams are perpendicular to the exterior wall, and the connection can be achieved using bolts rather than nails. However, when the floor beams are parallel to the exterior walls, V-shaped straps need to be attached to the floor and anchored to the wall, as shown in Figure 4.13b. It is important that straps

are sufficiently long and that the timber floor has an adequate tension capacity. The strap thickness should be 3 to 5 mm.

**2. Casting a new RC topping atop the existing floor:** A thin reinforced concrete topping (with a minimum thickness of 40 mm) reinforced with welded wire mesh can be placed atop an existing floor or roof, as shown in Figure 4.14a. The connection between the concrete topping and the existing timber floor should be adequately secured using a sufficient number of well-distributed nails.

**3. Installing new timber planks:** A layer of new timber planks can be laid perpendicular to the existing planks and nailed to the floor, as shown in Figure 4.14b.

**4. Diagonal bracing:** Floor structure can be stiffened by providing new diagonal braces made of timber or steel underneath the existing floor or roof. The braces must be anchored to the walls, as shown in Figure 4.15a.

**5. Casting a new RC slab:** In some cases, replacing an existing timber floor or roof with a reinforced concrete floor slab can be a realistic option from both the economic and structural perspective. An advantage of this solution is that it is low maintenance. However, a downside is that it adds significant weight to the building. It is important to ensure adequate bearing of the RC slab on the walls and anchorage between the RC slab and the walls by means of steel dowels, as shown in Figure 4.15b.

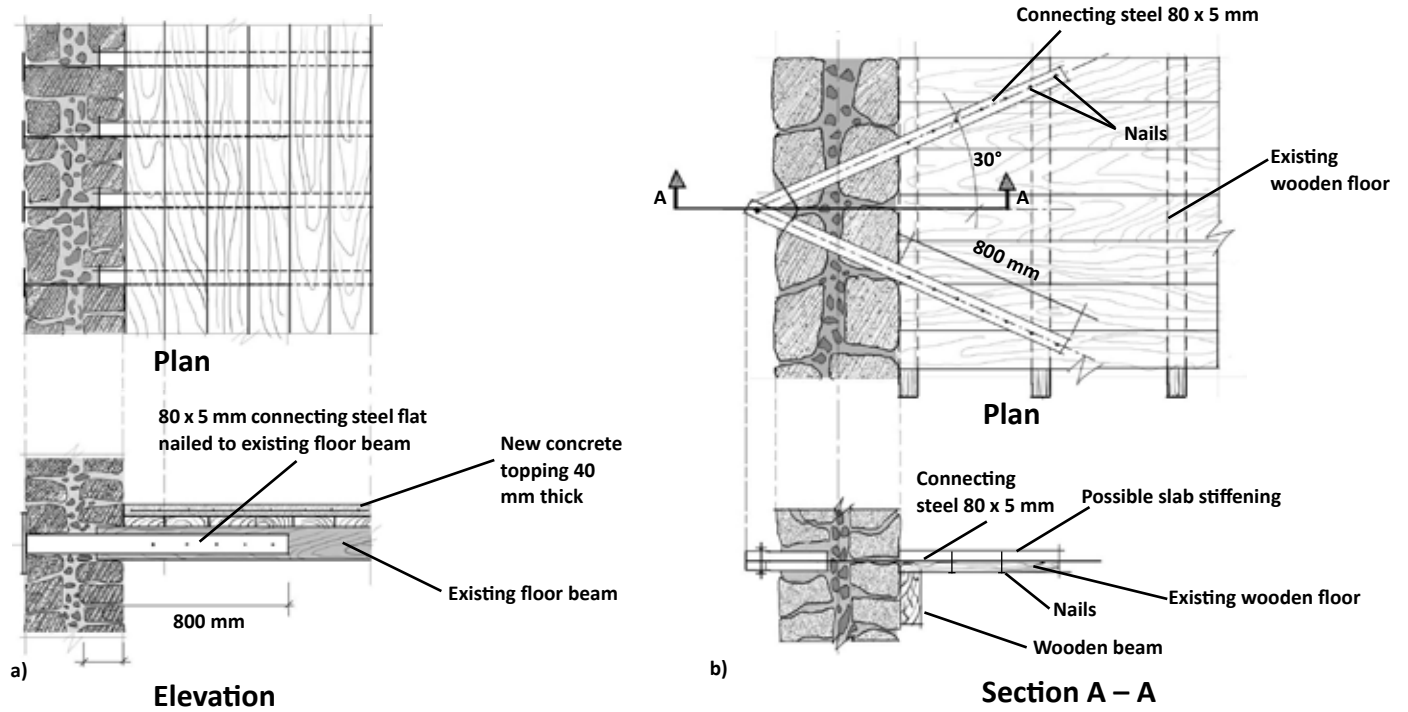

Figure 4.13 Steel straps for wall-to-floor anchorage: a) floor beams perpendicular to the wall, and b) floor beams parallel to the wall (source: UNIDO 1983)

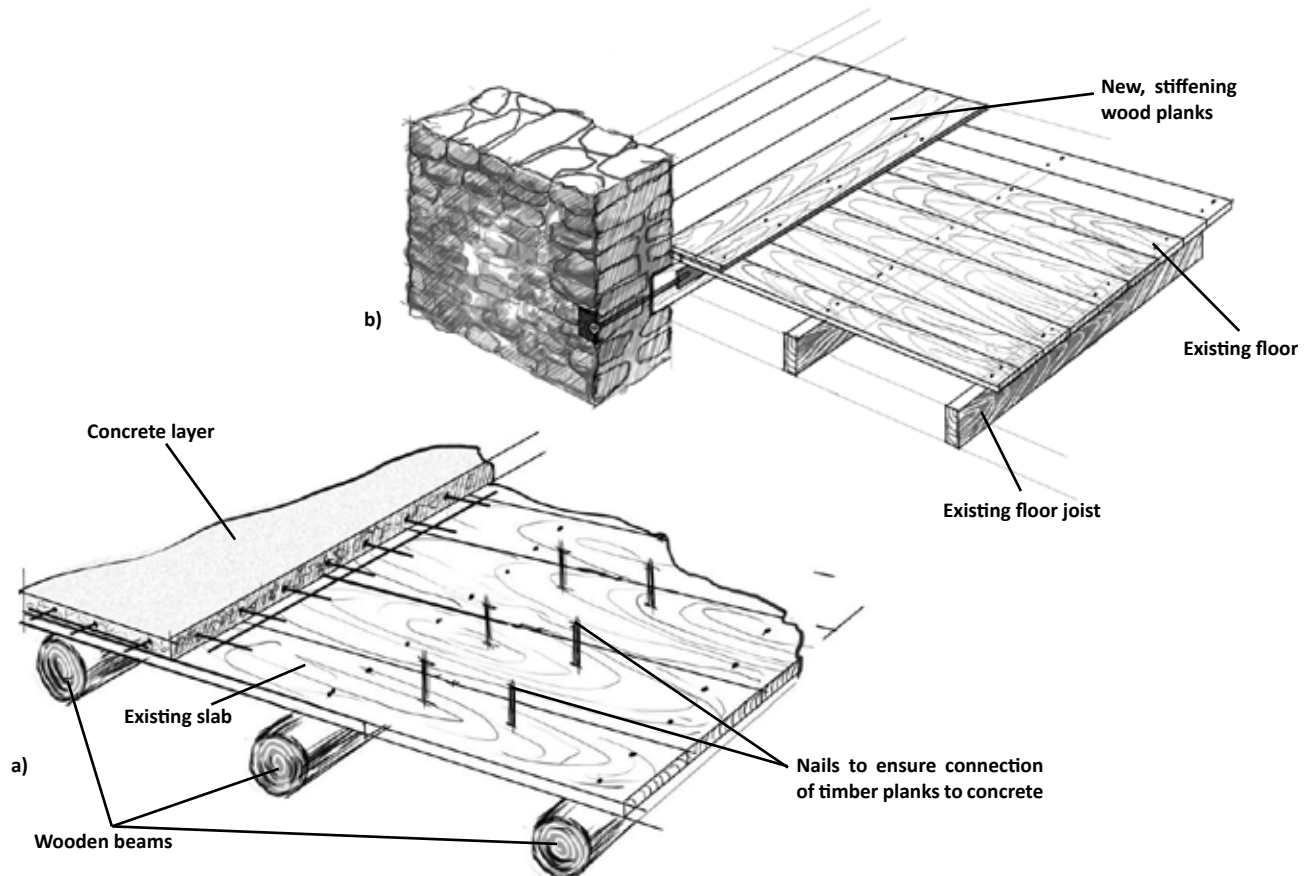

Figure 4.14 Stiffening the floor structures: a) RC topping, and b) new timber planks (source: UNIDO 1983)

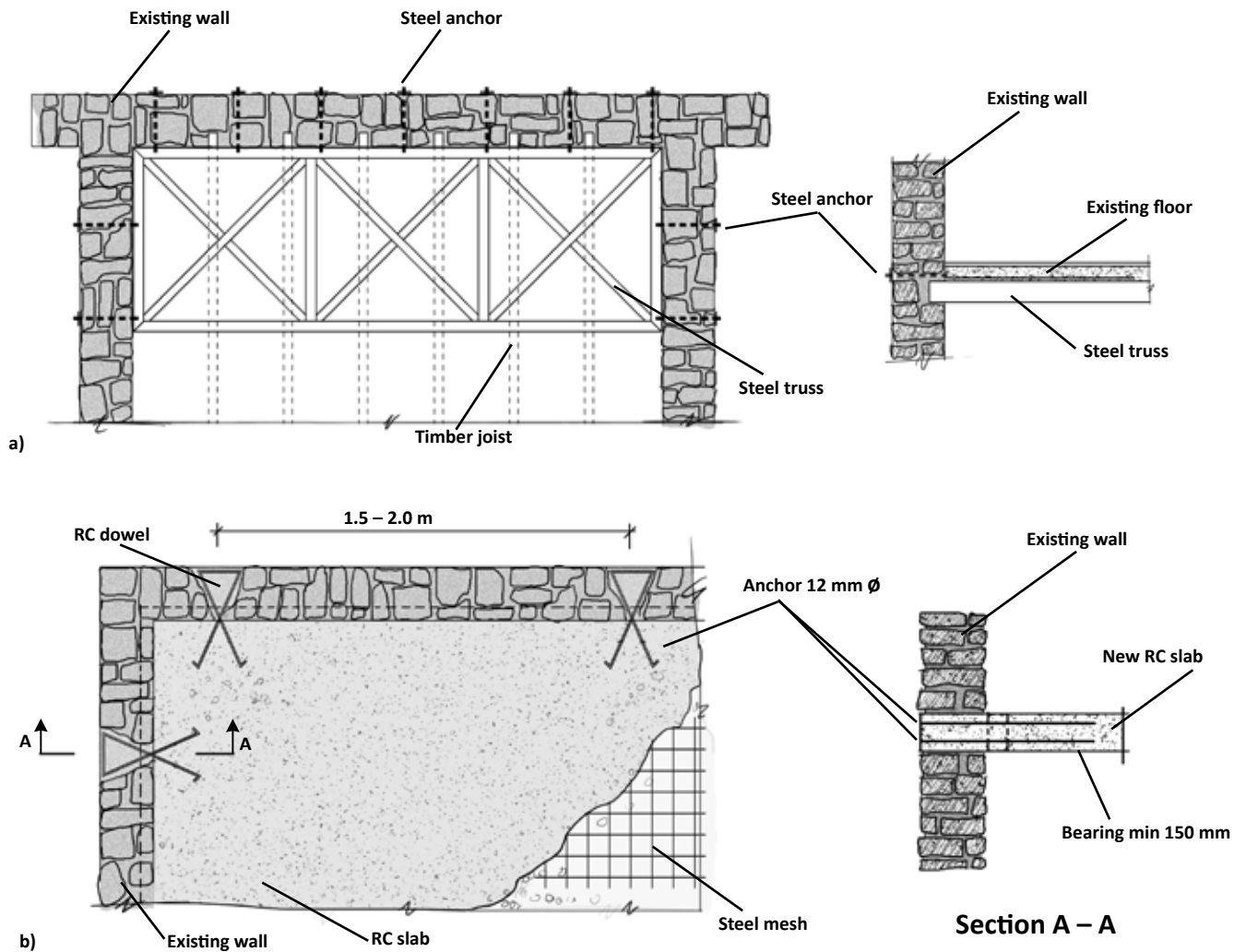

Figure 4.15 Retrofitting the floor and roof structures: a) diagonal braces, and b) a new RC slab (adapted from: Tomazevic 1999)

It is important to ensure that the new or retrofitted floor/roof structure is adequately anchored to the existing walls. For example, new RC topping can be anchored by embedding steel dowels into holes drilled into the wall and filled with epoxy or cementitious grout. Alternatively, dowels can be provided by embedding steel bars in holes filled with concrete, as shown in Figure 4.16. Dowel size and spacing depends on the seismic retrofit criteria. A typi-

cal detail used to retrofit stone masonry buildings in Italy after the 2002 Molise earthquake is shown in Figure 4.16 (Maffei et al. 2006).

Timber and steel roofs must be braced (Figure 4.17a). The integrity of a timber roof can be improved by tying roof components with straps and nailing them together. In the case of a two-sided pitched roof, collars should be provided to prevent spreading (Figure 4.17b).

*The integrity of a timber roof can be improved by tying roof components with straps and nailing them together.*

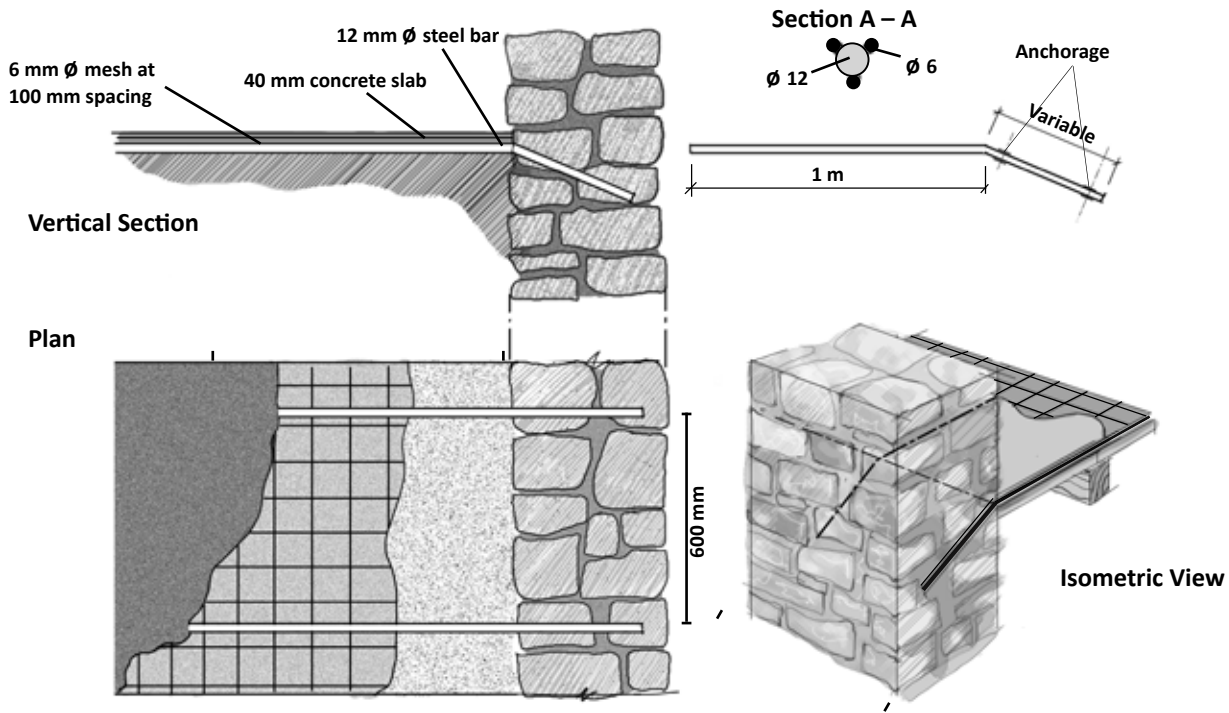

Figure 4.16 Wall-to-floor anchorage with steel dowels embedded into the wall (source: Maffei et al. 2006)

## Enhancing the Lateral Load Resistance of Stone masonry Walls

Commonly used wall retrofit techniques include the installation of through-stones and jacketing, which can be used to increase the wall strength both for in-plane (parallel to the wall length) and out-of-plane (perpendicular to the wall length) seismic effects. Other techniques include grouting and the installation of buttresses. Some of these techniques are discussed next.

### Through-stones

Reports from past earthquakes show that the wythes in stone masonry walls delaminate (separate) vertically down the middle due to the absence of through-stones, thereby causing disintegration of the interior and exterior wall wythes. In an extreme case, collapse of the entire building may occur. The causes of delamination are discussed in Chapter 2. Chances of wall delamination are considerably reduced when wall wythes are “stitched” together by means of through-stones. The purpose of this retrofit provision is to

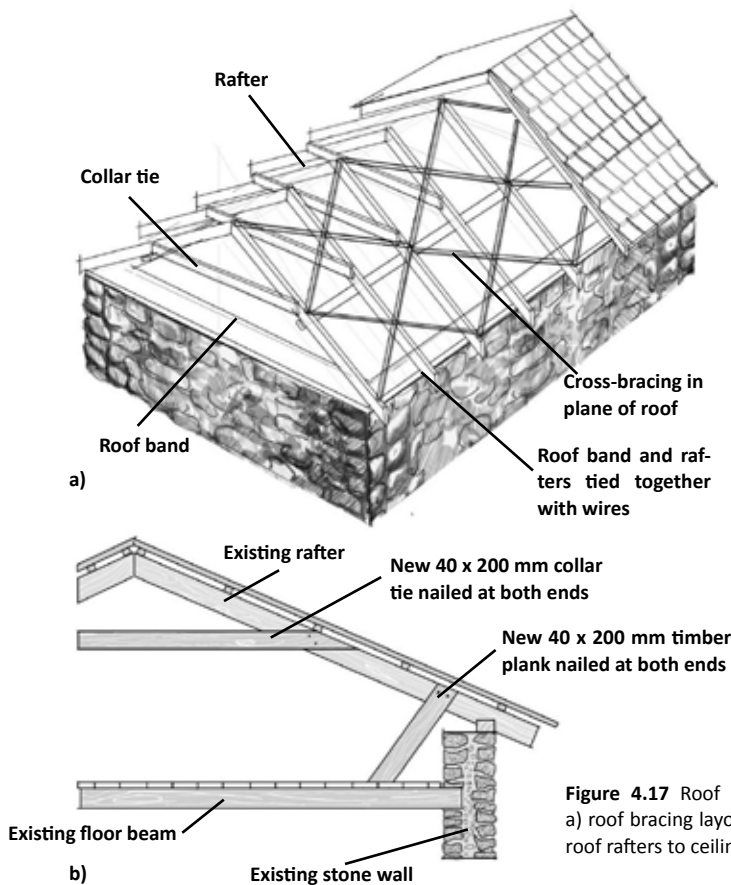

Figure 4.17 Roof bracing details: a) roof bracing layout, and b) tying roof rafters to ceiling joists

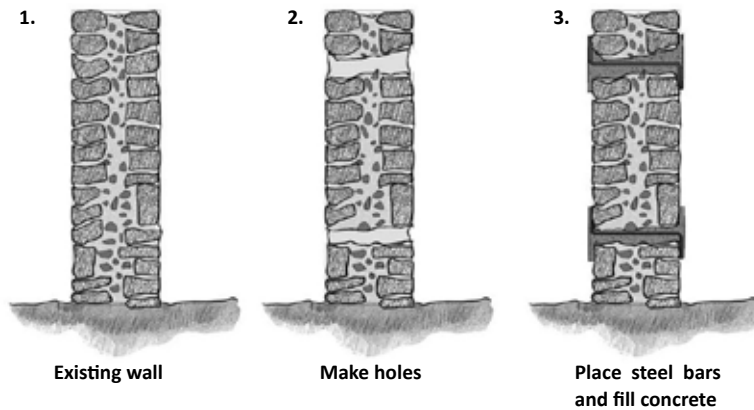
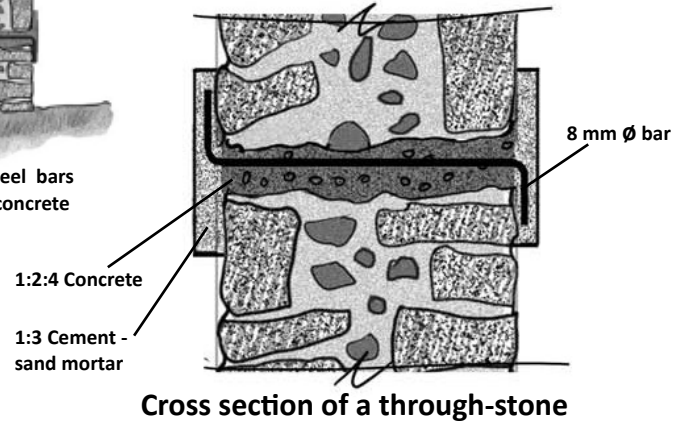

Figure 4.18 Procedure for the installation of through-stones (source: GOM 1998)



mimic good construction practice for stone masonry where long stones (bonding stones) are provided. The effectiveness of through-stones in new construction is discussed in Chapter 3.

The installation of through-stones is labor-intensive, but it may be a feasible retrofit option for stone masonry walls provided that the wall thickness is not excessively large. The procedure is illustrated in Figure 4.18. First, a hole needs to be created in the wall by removing stones. To create a hole, stones need to be loosened by means of gentle pushes sideways, upward and downward using a small crowbar, so that the other stones in the wall are not disturbed. The hole should be dumbbell-shaped, that is, it will be larger on the wall surfaces than in the

interior. A hooked steel bar needs to be installed and the hole should be filled with concrete. Finally, the exposed surface should be covered with a rich cement and sand plaster coating and cured for at least 14 days. Through-stones should be installed very carefully, otherwise surrounding portions of the wall may be damaged. Installation of through-stones in building applications is shown in Figures 4.19 and 4.20.



Figure 4.19 Examples of through-stone retrofit in Maharashtra, India: a) removing stone from the existing wall, and b) surface of a through-stone covered with a plaster (photos: S. Brzev)



Figure 4.20: Examples of completed through-stone retrofit projects in Maharashtra, India (photos: S. Brzev)

Through-wall anchors can also be used to create through-stones. These anchors were used to retrofit stone masonry walls after the 2002 Molise, Italy, earthquake (Maffei et al. 2006). Steel pipes of approx. 90 mm diameter and 4 mm thickness were installed into 130 mm diameter holes in the wall at 1500 mm spacing vertically and horizon-

tally, as shown in Figure 4.21 (note that spacing depends on the masonry strength and seismic zone at the site). The pipe sections had slotted holes cut in eight locations to ensure a good bond between the grout injected and the steel elements. Once these slotted pipes were installed, they were filled with grout.

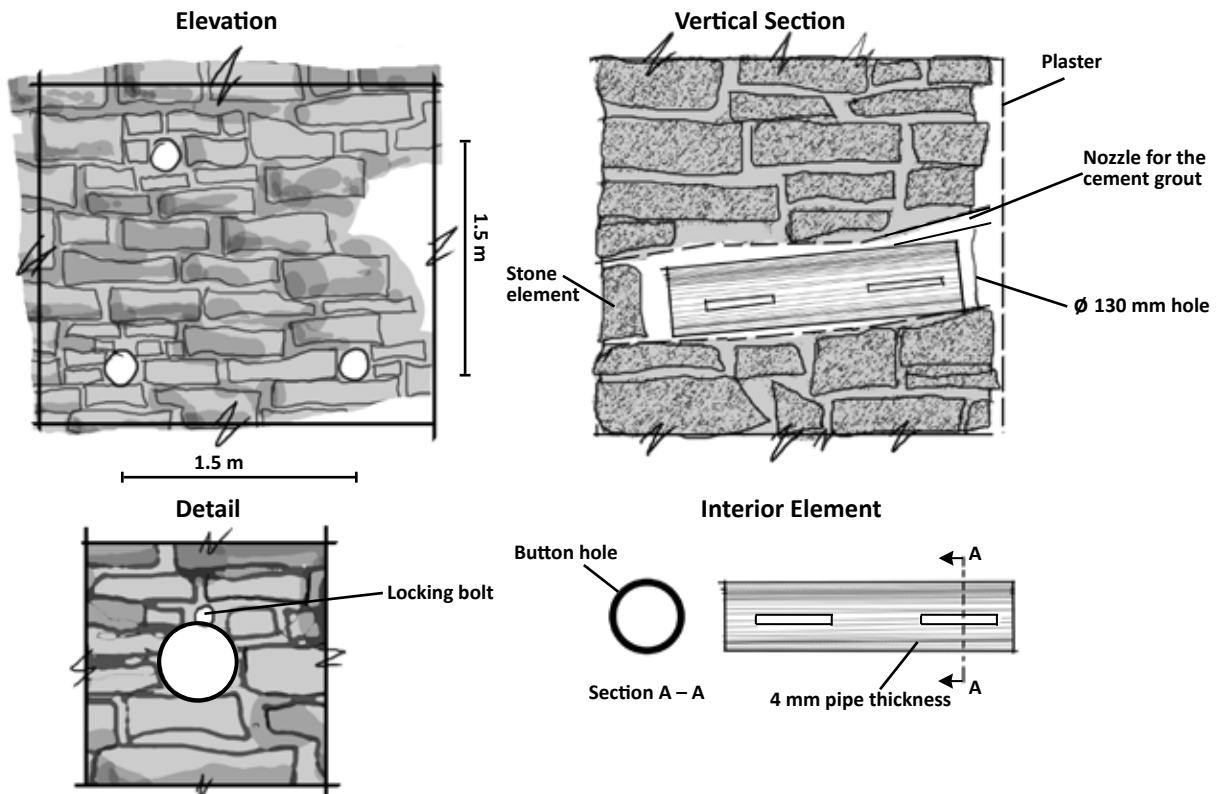

Figure 4.21 Installation of though-wall anchors in stone masonry walls after the 2002 Molise, Italy, earthquake (source: Maffei et al. 2006)

## Jacketing

Jacketing consists of covering the wall surface with a thin layer of reinforced mortar, micro-concrete, or shotcrete overlays interconnected by means of through-wall anchors. When properly implemented, jacketing provides confinement and ensures wall integrity for in-plane and out-of-plane seismic effects. Two retrofit provisions described earlier in this chapter, namely bandages and splints, represent localized applications of the jacketing technique.

Different materials can be used for jacketing, however the most common application includes the use of cement plaster or shotcrete reinforced by welded wire mesh (UNIDO, 1983). Jacketing consists of reinforced cement plaster (40 to 50 mm overall thickness) applied to the wall in two layers with welded wire steel mesh between them. Ideally, jacketing is applied on both the exterior and interior wall surfaces, and jacketed surfaces are connected by passing steel ties through the wall at 500 to 750 mm spacing horizontally and vertically (Figure 4.22). It is critical to prepare the wall surface before jacketing by removing existing plaster and dirt. An adequate bond between the new jacketed layer and the existing wall surface must be ensured. Figure 4.23 shows stone masonry buildings in Pakistan being jacketed.

The steel mesh should be continuous at wall intersections (this can be achieved by overlapping the mesh segments). It is critical that the mesh is anchored to

the floors below and above and the foundations. Figure 4.24 shows a stone masonry building in Slovenia being jacketed. Note the dowels extending from the floor structure below.

Jacketing causes an increase in the wall mass and stiffness. This in turn causes an increase in shear forces and overturning moments at the base of wall, which need to be transferred to foundations. In some cases, strengthening the foundations may be required.

*When properly implemented, jacketing enhances wall integrity for in-plane and out-of-plane seismic effects.*

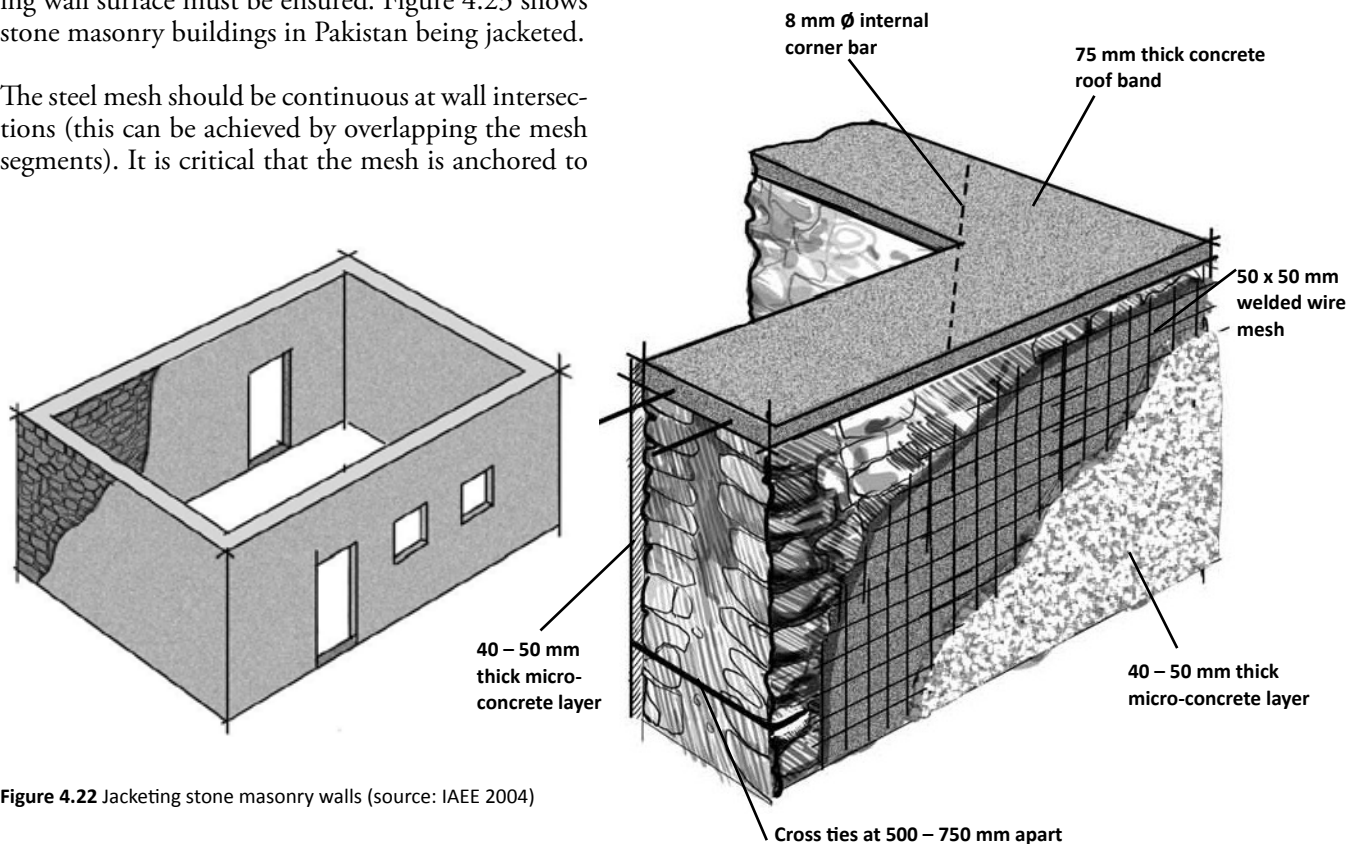
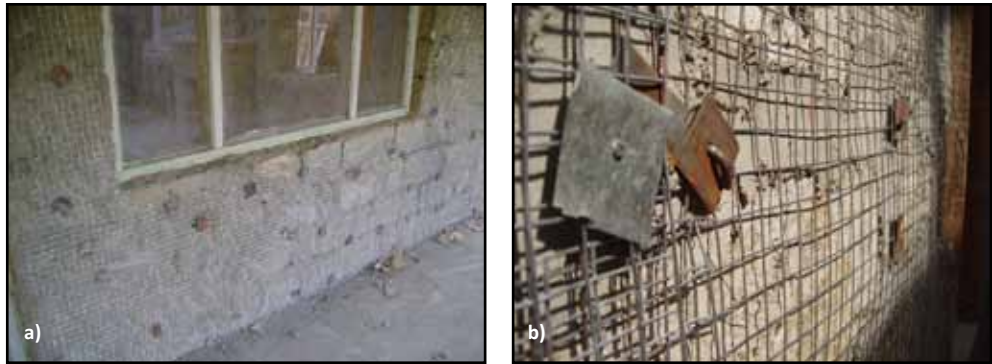
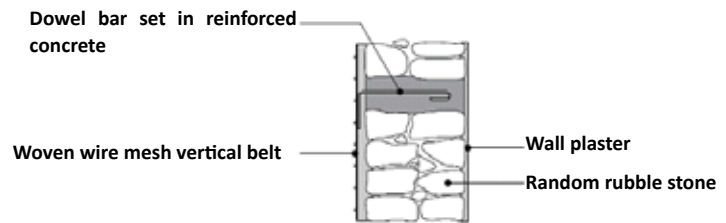

Figure 4.22 Jacketing stone masonry walls (source: IAEE 2004)

**Figure 4.23** Jacketing stone masonry buildings in Pakistan after the 2005 Kashmir earthquake: a) a wall surface showing reinforcement and anchors in place before the plaster application (photo: Q. Ali), and b) a detail of steel mesh reinforcement and through-wall anchors (photo: T. Schacher)



**Figure 4.24** Jacketing of a stone masonry wall in Slovenia (photo: M. Lutman)



**Figure 4.25** Single-sided jacketing showing steel dowels



**Figure 4.26** Testing polypropylene bands at IEM in Harbin, China (photo: W. Feng)

Ideally, jacketing should be applied to both interior and exterior wall surfaces, but this may not always be possible due to functional or financial constraints. In the case of a single-surface application, steel dowels of adequate size and spacing should be provided to ensure that the existing stone wall and the new jacket act in unison (Figure 4.25). However, it should be noted that the effectiveness of single-surface jacketing is significantly inferior to double-sided application because a single-sided jacket cannot confine the wall.

### An Alternative Technology: Polypropylene Bands

Mayorca et al. (2008) report on an approach where a closely-spaced mesh of polypropylene (PP) straps, an inexpensive material commonly used for packing, wraps around stone or adobe walls to increase their seismic performance. This approach has been tested at the University of Tokyo, and more recently at the Institute of Engineering Mechanics (IEM) of the China Earthquake Administration in Harbin, China (Figure 4.26). A non-profit organization in China, the China Development Research Foundation, is working with Professor Meguro to use this technology to strengthen stone masonry houses in Tibet. Training



**Figure 4.27** Grouting an existing stone masonry wall in Slovenia - note uniformly distributed holes at the location where grout is to be injected (photo: M. Lutman)

is being developed for local engineers, and a pilot program of strengthening 10 houses will be underway in spring 2011 (Feng 2010). An attempt was made to use these bands in rebuilding after the 2005 Pakistan earthquake, but the need for skillful use of a plastic melting gun proved to be a major constraint. For this reason, people preferred using steel wire mesh instead of the PP bands (Ali 2010).

## Grouting

Many voids exist in stone masonry walls, hence an appropriate method for strengthening the walls is by filling these voids by injecting cementitious grout. After hardening, the injected grout will bond the loose parts of the wall together into a solid structure. Cement-based grouting was first applied on a large scale in Italy and Slovenia after the 1976 Friuli, Italy, earthquake. The grout mix proportions may vary, but the common ingredients are Portland cement and pozzolana mixed with water. The grout is injected into the wall at low pressure through injection tubes and nozzles, which are built into the joints between the stones uniformly over the entire surface of the wall. For more details about this technique and experimental studies which confirmed its effectiveness, refer to To-

mazevic (1999) and Lutman and Tomazevic (2002). A stone masonry wall prepared for grouting is shown in Figure 4.27.

## Wall Buttresses

If a building has long unsupported walls, these walls may be vulnerable to the effects of out-of-plane earthquake forces, resulting in damage to or the collapse of the entire wall. This can be prevented by constructing new buttresses which provide lateral support to the wall (Figure 4.28). The concept of buttresses is introduced in Chapter 3. The spacing between buttresses should not exceed 5 m. It is critical to connect new buttresses with the existing wall by providing steel dowels anchored into the wall.

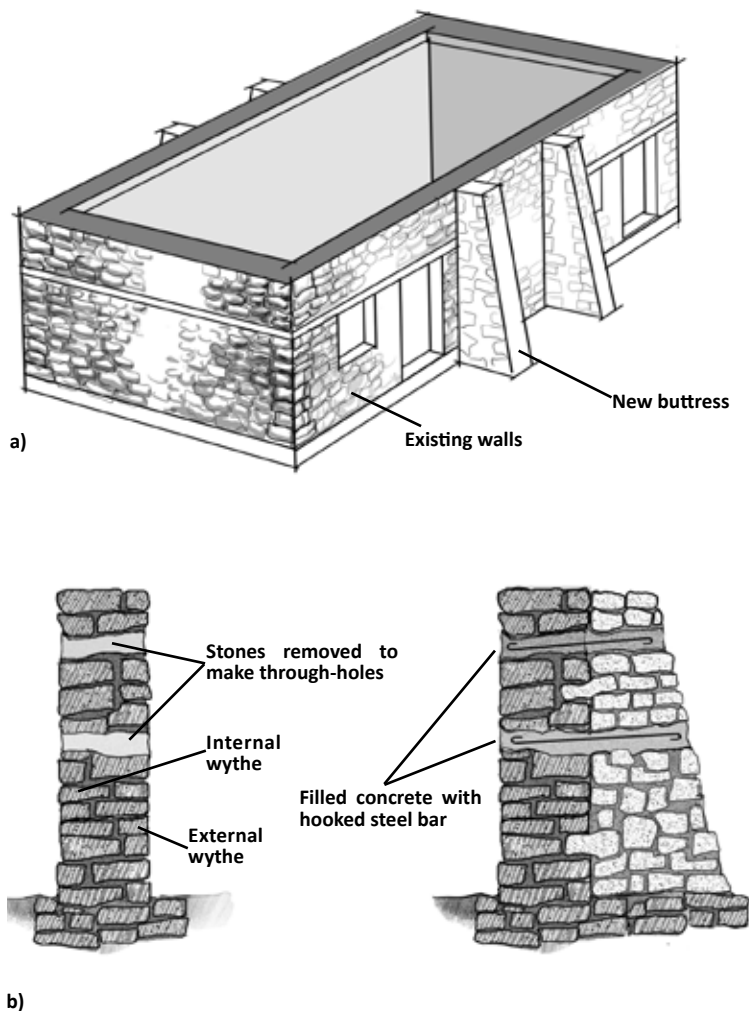

**Figure 4.28** Strengthening an existing stone wall with buttresses

## Strengthening Foundations

Strengthening existing foundations is a difficult and expensive task. A special investigation is recommended before any such intervention. A few foundation strengthening schemes are discussed in UNIDO (1983), GOM (1998), Tomazevic (1999), and IAEE (2004).

A foundation structure which has experienced differential settlement can be supported by underpinning. Underpinning can be carried out in phases by placing concrete blocks, as illustrated in Figure 4.29. Sliding movement of a foundation structure can be prevented by constructing new RC supporting beams. This method is especially feasible in sloping ground areas. These beams are constructed deep in the soil, toward the downward sloping side

of the foundation. In this way, the foundation is supported sideways and also underneath.

Sliding movements of a foundation structure can also be prevented by providing RC belts (tie beams) around the building at the foundation level, or by installing a tie beam along the inner side of the foundation (similar to an RC plinth band), also shown in Figure 4.29.

The continuity of longitudinal reinforcement bars should be ensured in all the above schemes. Foundation capacity can also be improved by providing a drainage apron around the building to avoid water seepage directly into the soil beneath the foundation. An example of foundation strengthening in Slovenia is shown in Figure 4.30.

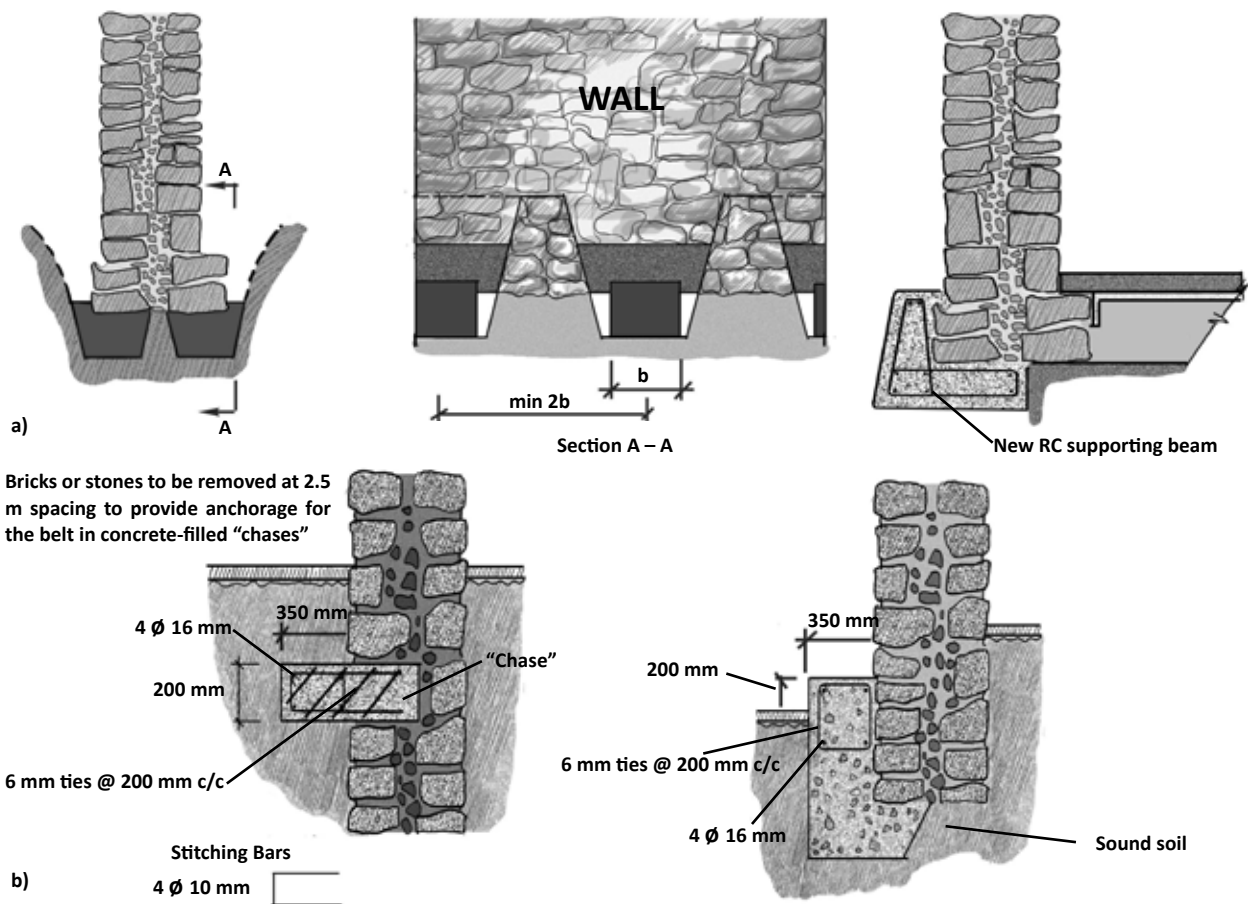

Figure 4.29 Strengthening existing foundations: a) underpinning the foundation, and b) external RC belt (adapted from: GOM 1998 and UNIDO 1983)



Figure 4.30 Strengthening a stone masonry foundation: a) reinforcement cage and formwork, and b) new reinforced concrete foundation under construction (photos: M. Lutman)

## 5. Conclusions

Stone masonry is one of the oldest and most common vernacular construction practices. Stone masonry construction varies widely around the world depending on the type of materials available locally, the level of artisan skills and tools, and economic constraints. In the past, stone masonry construction was used to build simple dwellings and also palaces, temples, and heritage landmark structures. It continues to be used for housing construction in developing countries and in areas where stone is a locally available and affordable building material.

Stone is one of the most durable construction materials, and many stone masonry buildings have remained in use for centuries. In many cases, earthquakes pose a major threat to these structures. The seismic vulnerability of stone masonry buildings is due to their heavy weight and, in most cases, the manner in which the walls have been built. Human and economic losses due to earthquakes are unacceptably high in areas where stone masonry has been used for house construction. Both old and new buildings of this construction type are at risk in earthquake-prone areas of the world.

This document explained the underlying causes for the poor seismic performance of stone masonry buildings and offers techniques for improving it for both new and existing buildings. The proposed techniques have been proven in field applications, are relatively simple, and can be applied in areas with limited artisan skills and tools. The authors of this document believe that there are two main challenges related to improving the seismic performance of stone masonry buildings: technical challenges and challenges related to the technology transfer.

### Technical Challenges

The satisfactory seismic performance of stone masonry buildings can be ensured by following three critical guidelines:

- Improve the quality of building materials and construction practices
- Ensure the integrity of building components to create a box-like effect during earthquake shaking

- Properly detail seismic provisions, such as seismic bands

It is often difficult to follow these guidelines in environments where the availability and level of artisan skills are very limited and there is no quality control during construction.

### Technology Transfer

The dissemination of knowledge on the earthquake-resistant construction of stone masonry buildings is a major challenge because of the informal nature of the construction process and the absence of input by qualified engineers and architects. Those involved in the construction process typically have a limited knowledge of earthquake-resistant construction. There is a widespread lack of understanding, at all levels, of the issues related to this type of construction and its seismic risk mitigation options. In most cases there is no mechanism to deliver available knowledge to the field. Even when the knowledge is delivered, it is very difficult to change traditional construction practices, and ensure the long-term implementation of new or modified technologies that are required for improved seismic performance of these buildings. Artisans and builders play a pivotal role in the process by acting as organizers, project planners, consultants, and contractors.

### Closing Remarks

Past earthquakes have revealed the extremely high vulnerability of stone masonry buildings, which resulted in unacceptably high human and economic losses. The authors of this document believe that by implementing the recommendations suggested here, the risk to the occupants of non-engineered stone masonry buildings and their property can be significantly reduced in future earthquakes.

This document will be useful to building professionals who want to learn more about this construction practice, either for the purpose of seismic mitigation or for post-earthquake reconstruction.



## 6. References

- Ali, Q., Naeem, A., Ashraf, M., Alam, B., Rehman, S., Fahim, M., and Awais, M., 2010. **Shake Table Tests on Typical Stone Masonry Buildings Used in the Himalayan Belt**, Paper No. 1414, Proceedings of the 9th U.S. National and 10th Canadian Conference on Earthquake Engineering, Toronto, Canada.
- BMTPC, 1994. **Retrofitting of Stone Masonry Houses in Marathwada Area of Maharashtra**, Building Materials and Technology Promotion Council, Ministry of Urban Development, Government of India, New Delhi, India.
- Bothara, J., Beetham, R., Brunson, D., Stannard, M., Brown, R., Hyland, C., Lewis, W., Miller, S., Sanders, R., and Sulistio, Y., 2010. **General Observations of Effects of the 30 September 2009 Padang Earthquake, Indonesia**, *Bulletin of the New Zealand Society for Earthquake Engineering*, Vol. 43, No. 3, 143–173.
- Bothara, J. K. and Hıçyılmaz, K., 2008. **General Observations of Building Behaviour during the 8th October 2005 Pakistan Earthquake**, *Bulletin of the New Zealand Society for Earthquake Engineering*, Vol. 41, No. 4, 209–233.
- Bothara, J. K., Guragain, R., and Dixit, A., 2002. **Protection of Educational Buildings Against Earthquakes: A Manual for Designers and Builders**, National Society for Earthquake Technology-Nepal, Kathmandu, Nepal.
- CBRI, 1994. **Pilot Project on Repairs and Strengthening of Earthquake Damaged Houses in Maharashtra**, Central Building Research Institute, Roorkee, India.
- Coburn, A., 1987. **Analysis of Earthquake Damage and Proposals for Strengthening Stone Masonry Buildings in Eastern Anatolia**, Proceedings, Middle East and Mediterranean Regional Conference on Earthen and Low-Strength Masonry Buildings in Seismic Areas, Middle East Technical University Research Center, Ankara, Turkey, 445–466.
- D’Ayala, D. and Speranza, E., 2002. **Single-Family Stone Masonry House**, World Housing Encyclopedia Report 28 (Italy), Earthquake Engineering Research Institute and International Association for Earthquake Engineering, www.world-housing.net.
- Decanini, L., De Sortis, A., Goretti, A., Langenbach, R., Mollaioli, F., and Rasulo, A., 2004. **Performance of Masonry Buildings During the 2002 Molise, Italy, Earthquake**, *Earthquake Spectra*, Vol. 20, Special Issue 1, S191–S220.
- Erdik, M., 1990. **The Earthquake Performance of Rural Stone Masonry Buildings in Turkey**, in *Earthquake Damage Evaluation and Vulnerability Analysis of Building Structures*, Omega Scientific, Wallingford, England, 57–77.
- Feng, W., 2010. “Seismic Retrofit of Rural Residence in Tibet”, China Development Research Foundation, (slide presentation obtained from personal communication).
- GOM, 1994. **Guidelines for Repair, Strengthening and Reconstruction of Houses Damaged in September 30, 1993 Earthquake in Maharashtra, India**, Project Management Unit, MEERP, Government of Maharashtra, Mumbai, India.
- GOM, 1998. **Manual for Earthquake-Resistant Construction and Seismic Strengthening of Buildings in Rural Areas of Maharashtra**, Revenue and Forests Department, Government of Maharashtra, Mumbai, India.
- GSDMA, 2001. **Guidelines for Reconstruction and New Construction of Houses in Kachchh Earthquake Affected Area of Gujarat**, Gujarat State Disaster Management Authority, Government of Gujarat, India.
- GSDMA, 2002. **Guidelines for Repair, Restoration and Retrofitting of Masonry Buildings in Kachchh Earthquake Affected Area of Gujarat**, Gujarat State Disaster Management Authority, Government of Gujarat, India.
- IAEE, 2004. **Guidelines for Earthquake-Resistant**

- Non-Engineered Construction**, International Association for Earthquake Engineering, Tokyo, Japan (first published in 1986 and reprinted by the National Information Center of Earthquake Engineering, IIT Kanpur).
- Jain, S. K., Lettis, W. R., Murty, C. V. R., Bardet, J., 2002. **Bhuj, India Earthquake of January 26, 2001: Reconnaissance Report**, *Earthquake Spectra*, Vol. 18, Supplement A.
- Lutman, M. and Tomazevic, M., 2002. **Rubble-Stone Masonry House**, World Housing Encyclopedia Report 58 (Slovenia), Earthquake Engineering Research Institute and International Association for Earthquake Engineering, www.world-housing.net.
- Maffei, J., Bazzurro, P., Marrow, J., and Goretti, A., 2002. **Recent Italian Earthquakes: Examination of Structural Vulnerability, Damage, and Post-Earthquake Practices – Case Studies and Comparisons to U.S. Practice**, Earthquake Engineering Research Institute, Oakland, CA.
- Mayorca, P., Navaratnaraj, S., and Meguro, K., 2008. **Report on the State of the Art in the Seismic Retrofitting of Unreinforced Masonry Houses by PP Band Meshes**, International Centre for Urban Safety Engineering, Institute of Industrial Science, University of Tokyo, Japan.
- Meyer, P., Ochsendorf, J., Germaine, J., and Kausel, E., 2007. **The Impact of High-Frequency/Low-Energy Seismic Waves on Unreinforced Masonry**, *Earthquake Spectra*, Vol. 23, No. 1, pp. 77–94.
- Momin, S. S., Nikolic-Brzev, S., and Bajoria, K. M., 1996. **Seismic Retrofitting of Stone Masonry Buildings Damaged in the September 1993 Earthquake in India**, Paper No. 1389, Proceedings, 11<sup>th</sup> World Conference on Earthquake Engineering, Acapulco, Mexico.
- Murty, C. V. R., 2005. **IITK-BMTPC Earthquake Tips: Learning Earthquake Design and Construction**, National Information Centre of Earthquake Engineering, IIT Kanpur, India, www.nicee.org.
- NSET and UOR, 2000. **Reconnaissance Report: Chamoli Earthquake of 29<sup>th</sup> March 1999, India**, Joint study by National Society for Earthquake Technology – Nepal and Department of Earthquake Engineering, University of Roorkee, India.
- Parajuli, Y., Bothara, J. K., and Upadhyay, B., 2002. **Uncoursed Rubble Stone Masonry Walls with Timber Floor and Roof**, World Housing Encyclopedia Report 74 (Nepal), Earthquake Engineering Research Institute and International Association for Earthquake Engineering, www.world-housing.net.
- Shadmon, A., 1996. **Stone: An Introduction**, 2<sup>nd</sup> ed., Practical Action and ITDG Publishing, London, England.
- Tassios, T. P. and Syrmakizis, K., 2002. **Load-Bearing Stone Masonry Building**, World Housing Encyclopedia Report 16 (Greece), Earthquake Engineering Research Institute and International Association for Earthquake Engineering, www.world-housing.net.
- Tomazevic, M., 1999. **Earthquake-Resistant Design of Masonry Buildings**, Imperial College Press, London, England.
- UNCRD, 2003. **Guidelines for Earthquake Resistant Design, Construction, and Retrofitting of Buildings in Afghanistan**, Ministry of Urban Development and Housing, Government of Afghanistan, and United Nations Centre for Regional Development, Disaster Management Planning Hyogo Office.
- UNIDO, 1983. **Repair and Strengthening of Reinforced Concrete, Stone and Brick Masonry Buildings**, *Building Construction Under Seismic Conditions in the Balkan Region*, Vol. 5, UNDP/UNIDO Project RER/79/015, United Nations Industrial Development Organization, Vienna, Austria.
- WHE, 2009. **World Housing Encyclopedia: An Encyclopedia of Housing Construction in Seismically Active Areas of the World**, www.world-housing.net.

## RELEVANT WORLD HOUSING ENCYCLOPEDIA REPORTS

(www.world-housing.net)

- Ahari, M. and Azarbakht, A., 2005. **Stonework building with wooden timber roof**, Report 114 (Iran).
- Al Dabbeek, J. and Al-Jawhari, A., 2002. **Unreinforced Concrete and Masonry Bearing Wall Construction (Designed for gravity loads only)**, Report 49 (Palestinian Territories).
- Ali, Q. and Muhammad, T., 2007. **Stone Masonry Residential Buildings**, Report 138 (Pakistan).
- Brzev, S., Greene, M., and Sinha, R., 2002. **Rubble Stone Masonry Walls with Timber Frame and Timber Roof**, Report 18 (India).
- D'Ayala, D. and Speranza, E., 2002. **Single-Family Stone Masonry House**, Report 28 (Italy).
- Farsi, M., Lazzali, F., and Ait-M, Y., 2002. **Stone Masonry Apartment Building**, Report 75 (Algeria).
- Lang, K. and Bachmann, H., 2007. **Urban Residential Buildings of the 19<sup>th</sup> Century in the City of Basel**, Report 119 (Switzerland).
- Lutman, M. and Tomazevic, M., 2002. **Rubble-Stone Masonry House**, Report 58 (Slovenia).
- Parajuli, Y., Bothara, J. K., and Upadhyay, B., 2002. **Traditional Oval-Shaped Rural Stone House**, Report 47 (Nepal).
- Parajuli, Y., Bothara, J. K., and Upadhyay, B., 2002. **Uncoursed Rubble Stone Masonry Walls with Timber Floor and Roof**, Report 74 (Nepal).
- Sinha, R. and Ambati, V., 2002. **Low-Strength Dressed Stone Masonry Buildings**, Report 80 (India).
- Sassu, M. and Cei, C., 2005. **Casa Torre Construction: Multistory Tower Masonry with Stone Pillars and Wood or Arched Beams**, Report 113 (Italy).
- Tassios, T. P. and Syrmakezis, K., 2002. **Load-Bearing Stone Masonry Building**, Report 16 (Greece).
- Vetturini, R., Cleri, A., Mollailoli, F., and Bazzurro, P., 2007. **Unreinforced Stone Wall Rural Housing (Upper Income)**, Report 120 (Italy).
- Vetturini, R., Mollailoli, F., and Bazzurro, P., 2007. **Unreinforced Stone Wall Rural Housing (Lower and Middle Class)**, Report 121 (Italy).



## 7. Glossary

**Bearing Wall:** A wall that carries (vertical) gravity loads due to floor and roof weight.

**Bed Joint:** The horizontal layer of mortar on which a stone is laid.

**Cover:** In a reinforced concrete member cover is a clear distance between the embedded reinforcement (link or tie) and the concrete surface. The main role of cover is to protect the reinforcement from corrosion.

**Cross Wall:** An interior wall that extends from the floor to the underside of the floor above or to the ceiling, securely fastened to each and capable of resisting lateral forces.

**Dead Load:** The weight of the building materials that make up a building, including its structure, enclosure and architectural finishes. The dead load is supported by the structure (walls, floors, and roof).

**Deformed bar:** A steel bar with projections or indentations for improved bonding with concrete. Preferably, deformed bars should be used for longitudinal reinforcement in RC members in seismic regions. In some countries, plain (smooth) steel bars without projections are still used for concrete construction.

**Delamination:** Bulging of exterior wythes in stone masonry walls due to earthquake shaking. Delamination usually leads to either partial or total wall collapse. Delamination is a common failure mechanism in stone masonry walls without through-stones.

**Gravity Load:** The load applied in vertical direction, including the weight of building materials (dead load), environmental loads such as snow, and moveable building contents (live load).

**Diaphragm:** A horizontal structural element (usually a suspended floor or ceiling or braced roof structure) that is strongly connected to the walls around it and distributes earthquake lateral forces to vertical elements, such as walls, of the lateral force resisting system. Diaphragms can be classified as flexible or rigid.

**Ductility:** The ability of a structure to deform by a

large amount without breaking or collapsing, even when it suffers overload and bends, sways, and deforms.

**Brittle:** A brittle material or structure fractures or suddenly breaks while subjected to bending, swaying, and deforming. A brittle structure has little tendency to deform before it fractures.

**Flexible Diaphragm:** A diaphragm which is so flexible it is unable to transfer the lateral loads to shear walls even if the floors/roof are well connected to the walls. Floors and roof constructed of timber, steel, or precast concrete without reinforced concrete topping fall in this category.

**In-Plane:** Seismic load acting along the wall length.

**Irregular Building:** A building that has a sudden change in the shape of plan is considered to have a horizontal irregularity. A building that changes shape up its height (such as setbacks or overhangs) or is missing significant load bearing walls is considered to have a vertical irregularity. It is not desirable for a building to be irregular—regular buildings perform better in earthquakes.

**Lateral Load:** Load acting in the horizontal direction; this load can be due to wind or earthquake effects.

**Lime Putty:** Slacked quicklime in the form of liquid slurry.

**Link:** A transverse reinforcing bar used to tie (confine) the longitudinal reinforcing bars together. A link acts like a belt, that is, it confines the cross-section of a reinforced concrete member. Links are used in horizontal RC members (beams or bands), while the term “tie” is used for transverse reinforcement in RC columns.

**Liquefaction:** An earthquake-induced phenomenon when saturated, loose, granular soils lose shear strength and behave as a liquid.

**Live Load:** The weight of all moveable contents of a building, including the occupants, furnishings, books and personal belongings that are supported by the structural system of the building.

**Load:** Active force (or combination of forces) exerted on a structure. The load can be classified, based on direction, into gravity (vertical) load and lateral (horizontal) load.

**Load Path:** A path through which vertical or seismic forces travel from the point of their origin to the foundation and, ultimately, to the supporting soil.

**Low-Strength Masonry:** Masonry laid in weak mortar; such as mud, weak cement/sand or lime/sand mortar.

**Out-of-Plane:** Seismic loading (earthquake shaking) acting normal (perpendicular) or at right-angle to the wall surface. Walls subjected to out-of-plane shaking are also known as face-loaded walls or transverse walls. Walls are weaker and less stable under out-of-plane than under in-plane seismic loads.

**Polypropylene Bands (PP Bands):** Similar to the straps used for securing boxes for shipping.

**Regular Building:** *see* Irregular Building.

**Rigid Diaphragm:** A suspended floor, roof or ceiling structure that is able to transfer lateral loads to the walls with negligible horizontal deformation of the diaphragm. Floors or roofs made from reinforced concrete, such as reinforced concrete slabs, fall into this category.

**Seismic Hazard:** The potential for damage caused by earthquakes. The level of hazard depends on the magnitude of probable earthquakes, the type of fault, the distance from faults associated with those earthquakes, and the type of soil at the site.

**Shear Wall:** A wall which is subjected to lateral loads due to wind or earthquake acting parallel to the direction of an earthquake load being considered (also known as an in-plane wall). Stone walls are stronger and stiffer in-plane than out-of-plane.

**Structural Elements:** Components of a building that provide gravity and lateral load resistance and are a part of a continuous load path. Walls are key structural elements in a stone masonry building.

**Stiffness:** Resistance to deformation. A stiff (rigid) wall does not deform much, even when subjected to significant lateral loads. Stone masonry walls are usually very stiff, as opposed to timber walls, which are flexible (the opposite of stiff).

**Transverse Wall:** *see* Cross Wall

**Unreinforced Masonry (URM) Wall:** A masonry wall containing no steel, timber, cane, or other reinforcement. An unreinforced wall resists gravity and lateral loads solely through the strength of the masonry materials.

**Wall:** Vertical, planar building element.

**Wythe:** A vertical leaf or layer of stone in a masonry wall. Stone masonry walls usually have two exterior wythes constructed using large stone boulders.

**Through-Stone:** A long stone that connects two wythes together in a stone masonry wall. It is also known as bond stone. Contrary to its name; a through-stone can also be a concrete block, a wood element, or steel bars with hooked ends embedded in concrete that perform the same function.



